

## Features

- 15 ns pin-to-pin logic delays on all pins
- $f_{CNT}$  to 95 MHz
- 288 macrocells with 6,400 usable gates
- Up to 166 user I/O pins
- 5V in-system programmable
  - Endurance of 10,000 program/erase cycles
  - Program/erase over full commercial voltage and temperature range
- Enhanced pin-locking architecture
- Flexible 36V18 Function Block
  - 90 product terms drive any or all of 18 macrocells within Function Block
  - Global and product term clocks, output enables, set and reset signals
- Extensive IEEE Std 1149.1 boundary-scan (JTAG) support
- Programmable power reduction mode in each macrocell
- Slew rate control on individual outputs
- User programmable ground pin capability
- Extended pattern security features for design protection
- High-drive 24 mA outputs
- 3.3V or 5V I/O capability
- Advanced CMOS 5V Fast FLASH™ technology
- Supports parallel programming of more than one XC9500 concurrently
- Available 352-pin BGA and 208-pin HQFP packages

## Description

The XC95288 is a high-performance CPLD providing advanced in-system programming and test capabilities for general purpose logic integration. It is comprised of eight 36V18 Function Blocks, providing 6,400 usable gates with propagation delays of 15 ns. See [Figure 2](#) for the architecture overview.

## Power Management

Power dissipation can be reduced in the XC95288 by configuring macrocells to standard or low-power modes of operation. Unused macrocells are turned off to minimize power dissipation.

Operating current for each design can be approximated for specific operating conditions using the following equation:

$$I_{CC} \text{ (mA)} = MC_{HP} (1.7) + MC_{LP} (0.9) + MC (0.006 \text{ mA/MHz}) f$$

Where:

$MC_{HP}$  = Macrocells in high-performance mode

$MC_{LP}$  = Macrocells in low-power mode

$MC$  = Total number of macrocells used

$f$  = Clock frequency (MHz)

[Figure 1](#) shows a typical calculation for the XC95288 device.

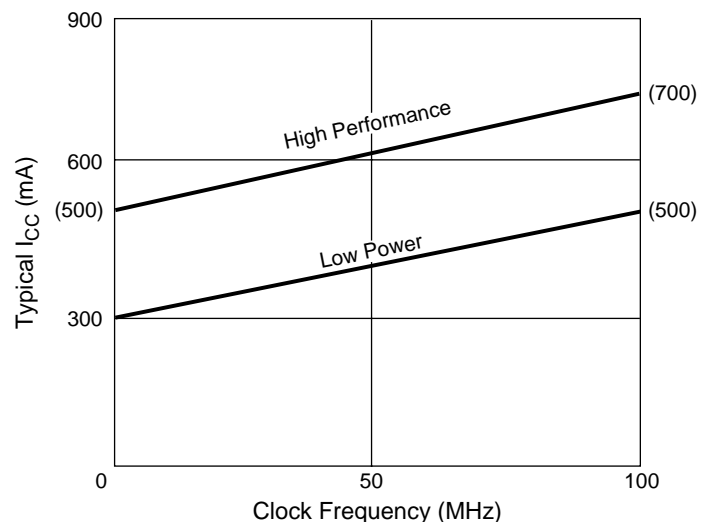

DS069\_01\_110101

Figure 1: Typical I<sub>CC</sub> vs. Frequency for XC95288

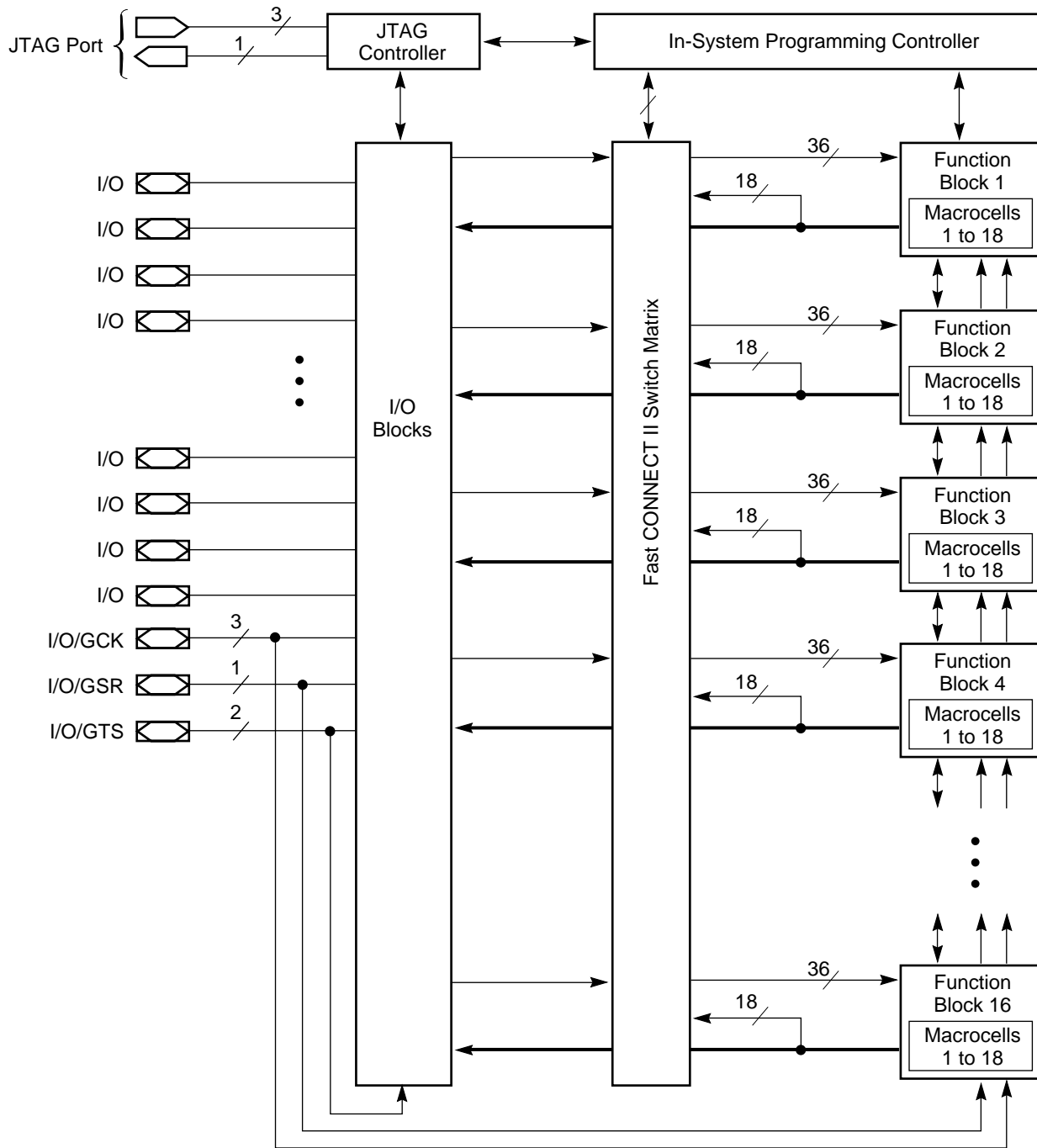

DS069\_02\_110101

**Figure 2: XC95288 Architecture**

Function block outputs (indicated by the bold line) drive the I/O blocks directly.

## Absolute Maximum Ratings

| Symbol    | Description                       | Value                  | Units |
|-----------|-----------------------------------|------------------------|-------|
| $V_{CC}$  | Supply voltage relative to GND    | -0.5 to 7.0            | V     |
| $V_{IN}$  | Input voltage relative to GND     | -0.5 to $V_{CC} + 0.5$ | V     |
| $V_{TS}$  | Voltage applied to 3-state output | -0.5 to $V_{CC} + 0.5$ | V     |
| $T_{STG}$ | Storage temperature (ambient)     | -65 to +150            | °C    |
| $T_J$     | Junction temperature              | +150                   | °C    |

### Notes:

- Stresses beyond those listed under Absolute Maximum Ratings may cause permanent damage to the device. These are stress ratings only, and functional operation of the device at these or any other conditions beyond those listed under Operating Conditions is not implied. Exposure to Absolute Maximum Ratings conditions for extended periods of time may affect device reliability.

## Recommended Operation Conditions

| Symbol      | Parameter  |   | Min  | Max               | Units |
|-------------|--|---|------|-------------------|-------|
| $V_{CCINT}$ | Supply voltage for internal logic and input buffers  | Commercial $T_A = 0^\circ\text{C}$ to $70^\circ\text{C}$    | 4.75 | 5.25              | V     |
|             |  | Industrial $T_A = -40^\circ\text{C}$ to $+85^\circ\text{C}$ | 4.5  | 5.5               |       |
| $V_{CCIO}$  | Supply voltage for output drivers for 5V operation   | Commercial $T_A = 0^\circ\text{C}$ to $70^\circ\text{C}$    | 4.75 | 5.25              | V     |
|             |  | Industrial $T_A = -40^\circ\text{C}$ to $+85^\circ\text{C}$ | 4.5  | 5.5               |       |
|             | Supply voltage for output drivers for 3.3V operation | 3.0   | 3.6  |                   |       |
| $V_{IL}$    | Low-level input voltage                              |   | 0    | 0.80              | V     |
| $V_{IH}$    | High-level input voltage                             |   | 2.0  | $V_{CCINT} + 0.5$ | V     |
| $V_O$       | Output voltage                                       |   | 0    | $V_{CCIO}$        | V     |

## Quality and Reliability Characteristics

| Symbol   | Parameter                        | Min    | Max | Units  |
|----------|----------------------------------|--------|-----|--------|
| $T_{DR}$ | Data Retention                   | 20     | -   | Years  |
| $N_{PE}$ | Program/Erase Cycles (Endurance) | 10,000 | -   | Cycles |

## DC Characteristic Over Recommended Operating Conditions

| Symbol   | Parameter   | Test Conditions   | Min           | Max      | Units         |
|----------|---|---|---------------|----------|---------------|
| $V_{OH}$ | Output high voltage for 5V outputs                | $I_{OH} = -4.0\text{ mA}$ , $V_{CC} = \text{Min}$         | 2.4           | -        | V             |
|          | Output high voltage for 3.3V outputs              | $I_{OH} = -3.2\text{ mA}$ , $V_{CC} = \text{Min}$         | 2.4           | -        | V             |
| $V_{OL}$ | Output low voltage for 5V outputs                 | $I_{OL} = 24\text{ mA}$ , $V_{CC} = \text{Min}$           | -             | 0.5      | V             |
|          | Output low voltage for 3.3V outputs               | $I_{OL} = 10\text{ mA}$ , $V_{CC} = \text{Min}$           | -             | 0.4      | V             |
| $I_{IL}$ | Input leakage current                             | $V_{CC} = \text{Max}$<br>$V_{IN} = \text{GND or } V_{CC}$ | -             | $\pm 10$ | $\mu\text{A}$ |
| $I_{IH}$ | I/O high-Z leakage current                        | $V_{CC} = \text{Max}$<br>$V_{IN} = \text{GND or } V_{CC}$ | -             | $\pm 10$ | $\mu\text{A}$ |
| $C_{IN}$ | I/O capacitance                                   | $V_{IN} = \text{GND}$<br>$f = 1.0\text{ MHz}$             | -             | 10       | pF            |
| $I_{CC}$ | Operating supply current (low power mode, active) | $V_I = \text{GND}$ , No load<br>$f = 1.0\text{ MHz}$      | 300 (Typical) |          | mA            |

## AC Characteristics

| Symbol             | Parameter   | XC95288-15 |      | XC95288-20 |      | Units |
|--------------------|---|------------|------|------------|------|-------|
|                    |   | Min        | Max  | Min        | Max  |       |
| $T_{PD}$           | I/O to output valid                                 | -          | 15.0 | -          | 20.0 | ns    |
| $T_{SU}$           | I/O setup time before GCK                           | 8.0        | -    | 10.0       | -    | ns    |
| $T_H$              | I/O hold time after GCK                             | 0          | -    | 0          | -    | ns    |
| $T_{CO}$           | GCK to output valid                                 | -          | 8.0  | -          | 10.0 | ns    |
| $f_{CNT}^{(1)}$    | 16-bit counter frequency                            | 95.2       | -    | 83.3       | -    | MHz   |
| $f_{SYSTEM}^{(2)}$ | Multiple FB internal operating frequency            | 55.6       | -    | 50.0       | -    | MHz   |
| $T_{PSU}$          | I/O setup time before p-term clock input            | 4.0        | -    | 4.0        | -    | ns    |
| $T_{PH}$           | I/O hold time after p-term clock input              | 4.0        | -    | 6.0        | -    | ns    |
| $T_{PCO}$          | P-term clock output valid                           | -          | 12.0 | -          | 16.0 | ns    |
| $T_{OE}$           | GTS to output valid                                 | -          | 11.0 | -          | 16.0 | ns    |
| $T_{OD}$           | GTS to output disable                               | -          | 11.0 | -          | 16.0 | ns    |
| $T_{POE}$          | Product term OE to output enabled                   | -          | 14.0 | -          | 18.0 | ns    |
| $T_{POD}$          | Product term OE to output disabled                  | -          | 14.0 | -          | 18.0 | ns    |
| $T_{WLH}$          | GCK pulse width (High or Low)                       | 5.5        | -    | 5.5        | -    | ns    |
| $T_{APRPW}$        | Asynchronous preset/reset pulse width (High or Low) | 8.0        | -    | 8.0        | -    | ns    |

### Notes:

- $f_{CNT}$  is the fastest 16-bit counter frequency available, using the local feedback when applicable.  
 $f_{CNT}$  is also the Export Control Maximum flip-flop toggle rate,  $f_{TOG}$ .
- $f_{SYSTEM}$  is the internal operating frequency for general purpose system designs spanning multiple FBs.

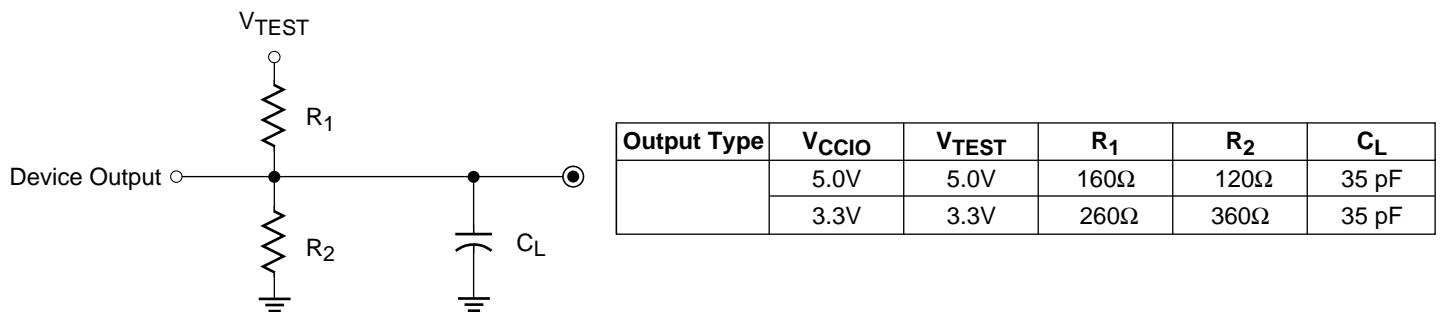

DS067\_03\_110101

Figure 3: AC Load Circuit

## Internal Timing Parameters

| Symbol  | Parameter                                | XC95288-15 |      | XC95288-20 |      | Units |
|---|--|------------|------|------------|------|-------|
|   |  | Min        | Max  | Min        | Max  |       |
| <b>Buffer Delays</b>                              |  |            |      |            |      |       |
| $T_{IN}$  | Input buffer delay                       | -          | 4.5  | -          | 6.5  | ns    |
| $T_{GCK}$   | GCK buffer delay                         | -          | 3.0  | -          | 3.0  | ns    |
| $T_{GSR}$   | GSR buffer delay                         | -          | 7.5  | -          | 9.5  | ns    |
| $T_{GTS}$   | GTS buffer delay                         | -          | 11.0 | -          | 16.0 | ns    |
| $T_{OUT}$   | Output buffer delay                      | -          | 4.5  | -          | 6.5  | ns    |
| $T_{EN}$  | Output buffer enable/disable delay       | -          | 0    | -          | 0    | ns    |
| <b>Product Term Control Delays</b>                |  |            |      |            |      |       |
| $T_{PTCK}$  | Product term clock delay                 | -          | 2.5  | -          | 2.5  | ns    |
| $T_{PTSR}$  | Product term set/reset delay             | -          | 3.0  | -          | 3.0  | ns    |
| $T_{PTTS}$  | Product term 3-state delay               | -          | 5.0  | -          | 5.0  | ns    |
| <b>Internal Register and Combinatorial Delays</b> |  |            |      |            |      |       |
| $T_{PDI}$   | Combinatorial logic propagation delay    | -          | 3.0  | -          | 4.0  | ns    |
| $T_{SUI}$   | Register setup time                      | 3.5        | -    | 3.5        | -    | ns    |
| $T_{HI}$  | Register hold time                       | 4.5        | -    | 6.5        | -    | ns    |
| $T_{COI}$   | Register clock to output valid time      | -          | 0.5  | -          | 0.5  | ns    |
| $T_{AOI}$   | Register async. S/R to output delay      | -          | 8.0  | -          | 8.0  | ns    |
| $T_{RAI}$   | Register async. S/R recover before clock | 10.0       | -    | 10.0       | -    | ns    |
| $T_{LOGI}$  | Internal logic delay                     | -          | 3.0  | -          | 3.0  | ns    |
| $T_{LOGILP}$                                      | Internal low power logic delay           | -          | 11.5 | -          | 11.5 | ns    |
| <b>Feedback Delays</b>                            |  |            |      |            |      |       |
| $T_F$   | Fast CONNECT II feedback delay           | -          | 11.0 | -          | 13.0 | ns    |
| $T_{LF}$  | Function block local feedback delay      | -          | 3.5  | -          | 5.0  | ns    |
| <b>Time Adders</b>                                |  |            |      |            |      |       |
| $T_{PTA}^{(1)}$                                   | Incremental product term allocator delay | -          | 1.0  | -          | 1.5  | ns    |
| $T_{SLEW}$  | Slew-rate limited delay                  | -          | 5.0  | -          | 5.5  | ns    |

**Notes:**

- $T_{PTA}$  is multiplied by the span of the function as defined in the XC9500 family data sheet.

## XC95288 I/O Pins

| Function Block | Macrocell | HQ208 | BG352 | BScan Order |
|----------------|-----------|-------|-------|-------------|
| 1              | 1         | –     | –     | 861         |
| 1              | 2         | 28    | N26   | 858         |
| 1              | 3         | 29    | P25   | 855         |
| 1              | 4         | –     | –     | 852         |
| 1              | 5         | 30    | P23   | 849         |
| 1              | 6         | 31    | P24   | 846         |
| 1              | 7         | –     | –     | 843         |
| 1              | 8         | 32    | R26   | 840         |
| 1              | 9         | –     | R25   | 837         |
| 1              | 10        | 33    | R24   | 834         |
| 1              | 11        | –     | R23   | 831         |
| 1              | 12        | 34    | T26   | 828         |
| 1              | 13        | –     | –     | 825         |
| 1              | 14        | 35    | T25   | 822         |
| 1              | 15        | 36    | T23   | 819         |
| 1              | 16        | –     | –     | 816         |
| 1              | 17        | 37    | V26   | 813         |
| 1              | 18        | –     | –     | 810         |
| 2              | 1         | –     | –     | 807         |
| 2              | 2         | 15    | K23   | 804         |
| 2              | 3         | 16    | K24   | 801         |
| 2              | 4         | –     | –     | 798         |
| 2              | 5         | 17    | J25   | 795         |
| 2              | 6         | 18    | L24   | 792         |
| 2              | 7         | –     | –     | 789         |
| 2              | 8         | 19    | K25   | 786         |
| 2              | 9         | –     | L25   | 783         |
| 2              | 10        | 20    | L26   | 780         |
| 2              | 11        | –     | M23   | 777         |
| 2              | 12        | 21    | M24   | 774         |
| 2              | 13        | –     | –     | 771         |
| 2              | 14        | 22    | M25   | 768         |
| 2              | 15        | 23    | M26   | 765         |
| 2              | 16        | –     | –     | 762         |
| 2              | 17        | 25    | N25   | 759         |
| 2              | 18        | –     | –     | 756         |

| Function Block | Macrocell         | HQ208             | BG352               | BScan Order        |
|----------------|-------------------|-------------------|---------------------|--------------------|
| 3              | 1                 | –                 | –                   | 753                |
| 3              | 2                 | 38                | U24                 | 750                |
| 3              | 3                 | 39                | U23                 | 747                |
| 3              | 4                 | –                 | –                   | 744                |
| 3              | 5                 | 40                | Y26                 | 741                |
| 3              | 6                 | 41                | W25                 | 738                |
| 3              | 7                 | –                 | –                   | 735                |
| 3              | 8                 | 43                | AA26                | 732                |
| 3              | 9                 | –                 | Y25                 | 729                |
| 3              | 10                | 44 <sup>[1]</sup> | Y24 <sup>[1]</sup>  | 726 <sup>[1]</sup> |
| 3              | 11                | –                 | AA25                | 723                |
| 3              | 12                | 45                | AB25                | 720                |
| 3              | 13                | –                 | –                   | 717                |
| 3              | 14 <sup>[1]</sup> | 46 <sup>[1]</sup> | AA24 <sup>[1]</sup> | 714                |
| 3              | 15                | 47                | Y23                 | 711                |
| 3              | 16                | –                 | –                   | 708                |
| 3              | 17                | 48                | AC26                | 705                |
| 3              | 18                | –                 | –                   | 702                |
| 4              | 1                 | –                 | –                   | 699                |
| 4              | 2 <sup>[1]</sup>  | 3 <sup>[1]</sup>  | E23 <sup>[1]</sup>  | 696                |
| 4              | 3                 | 4                 | C26                 | 693                |
| 4              | 4                 | –                 | –                   | 690                |
| 4              | 5 <sup>[1]</sup>  | 5 <sup>[1]</sup>  | E24 <sup>[1]</sup>  | 687                |
| 4              | 6                 | 6                 | F24                 | 684                |
| 4              | 7                 | –                 | –                   | 681                |
| 4              | 8 <sup>[1]</sup>  | 7 <sup>[1]</sup>  | E25 <sup>[1]</sup>  | 678                |
| 4              | 9                 | –                 | D26                 | 675                |
| 4              | 10                | 8                 | G24                 | 672                |
| 4              | 11                | –                 | F25                 | 669                |
| 4              | 12 <sup>[1]</sup> | 9 <sup>[1]</sup>  | F26 <sup>[1]</sup>  | 666                |
| 4              | 13                | –                 | –                   | 663                |
| 4              | 14                | 10                | H23                 | 660                |
| 4              | 15                | 12                | G26                 | 657                |
| 4              | 16                | –                 | –                   | 654                |
| 4              | 17                | 14                | H25                 | 651                |
| 4              | 18                | –                 | –                   | 648                |

### Notes:

1. Global control pin.

**XC95288 I/O Pins (Continued)**

| Function Block | Macrocell         | HQ208              | BG352               | BScan Order |
|----------------|-------------------|--------------------|---------------------|-------------|
| 5              | 1                 | –                  | –                   | 645         |
| 5              | 2                 | 49                 | AA23                | 642         |
| 5              | 3                 | 50                 | AB24                | 639         |
| 5              | 4                 | –                  | –                   | 636         |
| 5              | 5                 | 51                 | AD25                | 633         |
| 5              | 6                 | 54                 | AE24                | 630         |
| 5              | 7                 | –                  | –                   | 627         |
| 5              | 8 <sup>[1]</sup>  | 55 <sup>[1]</sup>  | AD23 <sup>[1]</sup> | 624         |
| 5              | 9                 | –                  | AC22                | 621         |
| 5              | 10                | 56                 | AF24                | 618         |
| 5              | 11                | –                  | AD22                | 615         |
| 5              | 12                | 57                 | AE23                | 612         |
| 5              | 13                | –                  | –                   | 609         |
| 5              | 14                | 58                 | AE22                | 606         |
| 5              | 15                | 60                 | AE21                | 603         |
| 5              | 16                | –                  | –                   | 600         |
| 5              | 17                | 61                 | AF21                | 597         |
| 5              | 18                | –                  | –                   | 594         |
| 6              | 1                 | –                  | –                   | 591         |
| 6              | 2                 | 197                | C19                 | 588         |
| 6              | 3                 | 198                | D18                 | 585         |
| 6              | 4                 | –                  | –                   | 582         |
| 6              | 5                 | 199                | A21                 | 579         |
| 6              | 6                 | 200                | B20                 | 576         |
| 6              | 7                 | –                  | –                   | 573         |
| 6              | 8                 | 201                | C20                 | 570         |
| 6              | 9                 | –                  | B21                 | 567         |
| 6              | 10                | 202                | B22                 | 564         |
| 6              | 11                | –                  | C21                 | 561         |
| 6              | 12                | 203                | D20                 | 558         |
| 6              | 13                | –                  | –                   | 555         |
| 6              | 14                | 205                | B24                 | 552         |
| 6              | 15 <sup>[1]</sup> | 206 <sup>[1]</sup> | C23 <sup>[1]</sup>  | 549         |
| 6              | 16                | –                  | –                   | 546         |
| 6              | 17                | 208                | D22                 | 543         |
| 6              | 18                | –                  | –                   | 540         |

| Function Block | Macrocell | HQ208 | BG352 | BScan Order |
|----------------|-----------|-------|-------|-------------|
| 7              | 1         | –     | –     | 537         |
| 7              | 2         | 62    | AC19  | 534         |
| 7              | 3         | 63    | AD19  | 531         |
| 7              | 4         | –     | –     | 528         |
| 7              | 5         | 64    | AE20  | 525         |
| 7              | 6         | 66    | AC18  | 522         |
| 7              | 7         | –     | –     | 519         |
| 7              | 8         | 67    | AD18  | 516         |
| 7              | 9         | –     | AE19  | 513         |
| 7              | 10        | 69    | AD17  | 510         |
| 7              | 11        | –     | AE18  | 507         |
| 7              | 12        | 70    | AF18  | 504         |
| 7              | 13        | –     | –     | 501         |
| 7              | 14        | 71    | AE17  | 498         |
| 7              | 15        | 72    | AE16  | 495         |
| 7              | 16        | –     | –     | 492         |
| 7              | 17        | 73    | AF16  | 489         |
| 7              | 18        | –     | –     | 486         |
| 8              | 1         | –     | –     | 483         |
| 8              | 2         | 186   | A15   | 480         |
| 8              | 3         | 187   | B15   | 477         |
| 8              | 4         | –     | –     | 474         |
| 8              | 5         | 188   | C15   | 471         |
| 8              | 6         | 189   | D15   | 468         |
| 8              | 7         | –     | –     | 465         |
| 8              | 8         | 191   | A16   | 462         |
| 8              | 9         | –     | B16   | 459         |
| 8              | 10        | 192   | C16   | 456         |
| 8              | 11        | –     | B17   | 453         |
| 8              | 12        | 193   | C17   | 450         |
| 8              | 13        | –     | –     | 447         |
| 8              | 14        | 194   | B18   | 444         |
| 8              | 15        | 195   | A20   | 441         |
| 8              | 16        | –     | –     | 438         |
| 8              | 17        | 196   | B19   | 435         |
| 8              | 18        | –     | –     | 432         |

**Notes:**

1. Global control pin.

## XC95288 I/O Pins (Continued)

| Function Block | Macrocell | HQ208 | BG352 | BScan Order |
|----------------|-----------|-------|-------|-------------|
| 9              | 1         | –     | –     | 429         |
| 9              | 2         | 74    | AE14  | 426         |
| 9              | 3         | 75    | AF14  | 423         |
| 9              | 4         | –     | –     | 420         |
| 9              | 5         | 76    | AE13  | 417         |
| 9              | 6         | 77    | AC13  | 414         |
| 9              | 7         | –     | –     | 411         |
| 9              | 8         | 78    | AD13  | 408         |
| 9              | 9         | –     | AF12  | 405         |
| 9              | 10        | 80    | AE12  | 402         |
| 9              | 11        | 82    | AD12  | 399         |
| 9              | 12        | 83    | AC12  | 396         |
| 9              | 13        | –     | –     | 393         |
| 9              | 14        | 84    | AF11  | 390         |
| 9              | 15        | 85    | AE11  | 387         |
| 9              | 16        | –     | –     | 384         |
| 9              | 17        | 86    | AE9   | 381         |
| 9              | 18        | –     | –     | 378         |
| 10             | 1         | –     | –     | 375         |
| 10             | 2         | 170   | C10   | 372         |
| 10             | 3         | 171   | B9    | 369         |
| 10             | 4         | –     | –     | 366         |
| 10             | 5         | 173   | A9    | 363         |
| 10             | 6         | 174   | D11   | 360         |
| 10             | 7         | –     | –     | 357         |
| 10             | 8         | 175   | B11   | 354         |
| 10             | 9         | –     | A11   | 351         |
| 10             | 10        | 178   | C12   | 348         |
| 10             | 11        | 179   | B12   | 345         |
| 10             | 12        | 180   | A12   | 342         |
| 10             | 13        | –     | –     | 339         |
| 10             | 14        | 182   | A13   | 336         |
| 10             | 15        | 183   | B14   | 333         |
| 10             | 16        | –     | –     | 330         |
| 10             | 17        | 185   | C14   | 327         |
| 10             | 18        | –     | –     | 324         |

| Function Block | Macrocell | HQ208 | BG352 | BScan Order |
|----------------|-----------|-------|-------|-------------|
| 11             | 1         | –     | –     | 321         |
| 11             | 2         | 87    | AD9   | 318         |
| 11             | 3         | 88    | AC10  | 315         |
| 11             | 4         | –     | –     | 312         |
| 11             | 5         | 89    | AF7   | 309         |
| 11             | 6         | 90    | AE8   | 306         |
| 11             | 7         | –     | –     | 303         |
| 11             | 8         | 91    | AD8   | 300         |
| 11             | 9         | –     | AE7   | 297         |
| 11             | 10        | 95    | AD7   | 294         |
| 11             | 11        | 97    | AE5   | 291         |
| 11             | 12        | 99    | AC7   | 288         |
| 11             | 13        | –     | –     | 285         |
| 11             | 14        | 100   | AE3   | 282         |
| 11             | 15        | 101   | AD4   | 279         |
| 11             | 16        | –     | –     | 276         |
| 11             | 17        | 102   | AC5   | 273         |
| 11             | 18        | –     | –     | 270         |
| 12             | 1         | –     | –     | 267         |
| 12             | 2         | 158   | B3    | 264         |
| 12             | 3         | 159   | A3    | 261         |
| 12             | 4         | –     | –     | 258         |
| 12             | 5         | 160   | D6    | 255         |
| 12             | 6         | 161   | C6    | 252         |
| 12             | 7         | –     | –     | 249         |
| 12             | 8         | 162   | B5    | 246         |
| 12             | 9         | –     | A4    | 243         |
| 12             | 10        | 164   | B6    | 240         |
| 12             | 11        | 165   | A6    | 237         |
| 12             | 12        | 166   | D8    | 234         |
| 12             | 13        | –     | –     | 231         |
| 12             | 14        | 167   | B7    | 228         |
| 12             | 15        | 168   | A7    | 225         |
| 12             | 16        | –     | –     | 222         |
| 12             | 17        | 169   | D9    | 219         |
| 12             | 18        | –     | –     | 216         |



## XC95288 I/O Pins (Continued)

| Function Block | Macrocell | HQ208 | BG352 | BScan Order |
|----------------|-----------|-------|-------|-------------|
| 13             | 1         | –     | –     | 213         |
| 13             | 2         | 103   | AD3   | 210         |
| 13             | 3         | 106   | AD2   | 207         |
| 13             | 4         | –     | –     | 204         |
| 13             | 5         | 107   | AC3   | 201         |
| 13             | 6         | 109   | AD1   | 198         |
| 13             | 7         | –     | –     | 195         |
| 13             | 8         | 110   | AA4   | 192         |
| 13             | 9         | –     | AA3   | 189         |
| 13             | 10        | 111   | AB2   | 186         |
| 13             | 11        | 112   | AC1   | 183         |
| 13             | 12        | 113   | AA2   | 180         |
| 13             | 13        | –     | –     | 177         |
| 13             | 14        | 114   | AA1   | 174         |
| 13             | 15        | 115   | Y1    | 171         |
| 13             | 16        | –     | –     | 168         |
| 13             | 17        | 116   | V4    | 165         |
| 13             | 18        | –     | –     | 162         |
| 14             | 1         | –     | –     | 159         |
| 14             | 2         | 144   | K3    | 156         |
| 14             | 3         | 145   | G1    | 153         |
| 14             | 4         | –     | –     | 150         |
| 14             | 5         | 146   | H2    | 147         |
| 14             | 6         | 147   | H3    | 144         |
| 14             | 7         | –     | –     | 141         |
| 14             | 8         | 148   | J4    | 138         |
| 14             | 9         | –     | F1    | 135         |
| 14             | 10        | 149   | G2    | 132         |
| 14             | 11        | 150   | G3    | 129         |
| 14             | 12        | 151   | F2    | 126         |
| 14             | 13        | –     | –     | 123         |
| 14             | 14        | 152   | E2    | 120         |
| 14             | 15        | 154   | D2    | 117         |
| 14             | 16        | –     | –     | 114         |
| 14             | 17        | 155   | F4    | 111         |
| 14             | 18        | –     | –     | 108         |

| Function Block | Macrocell | HQ208 | BG352 | BScan Order |
|----------------|-----------|-------|-------|-------------|
| 15             | 1         | –     | –     | 105         |
| 15             | 2         | 117   | V3    | 102         |
| 15             | 3         | 118   | W2    | 99          |
| 15             | 4         | –     | –     | 96          |
| 15             | 5         | 119   | U4    | 93          |
| 15             | 6         | 120   | U3    | 90          |
| 15             | 7         | –     | –     | 87          |
| 15             | 8         | 121   | V2    | 84          |
| 15             | 9         | –     | V1    | 81          |
| 15             | 10        | 122   | U2    | 78          |
| 15             | 11        | 123   | T2    | 75          |
| 15             | 12        | 125   | R4    | 72          |
| 15             | 13        | –     | –     | 69          |
| 15             | 14        | 126   | R3    | 66          |
| 15             | 15        | 127   | R2    | 63          |
| 15             | 16        | –     | –     | 60          |
| 15             | 17        | 128   | R1    | 57          |
| 15             | 18        | –     | –     | 54          |
| 16             | 1         | –     | –     | 51          |
| 16             | 2         | 131   | P1    | 48          |
| 16             | 3         | 133   | N2    | 45          |
| 16             | 4         | –     | –     | 42          |
| 16             | 5         | 134   | N4    | 39          |
| 16             | 6         | 135   | N3    | 36          |
| 16             | 7         | –     | –     | 33          |
| 16             | 8         | 136   | M1    | 30          |
| 16             | 9         | –     | M2    | 27          |
| 16             | 10        | 137   | M3    | 24          |
| 16             | 11        | 138   | M4    | 21          |
| 16             | 12        | 139   | L1    | 18          |
| 16             | 13        | –     | –     | 15          |
| 16             | 14        | 140   | L2    | 12          |
| 16             | 15        | 142   | L3    | 9           |
| 16             | 16        | –     | –     | 6           |
| 16             | 17        | 143   | J1    | 3           |
| 16             | 18        | –     | –     | 0           |

## XC95288 Global, JTAG, and Power Pins

| Pin Type           | HQ208   | BG352   |
|--------------------|---|---|
| I/O/GCK1           | 44  | Y24   |
| I/O/GCK2           | 46  | AA24  |
| I/O/GCK3           | 55  | AD23  |
| I/O/GTS1           | 7   | E25   |
| I/O/GTS2           | 9   | F26   |
| I/O/GTS3           | 3   | E23   |
| I/O/GTS4           | 5   | E24   |
| I/O/GSR            | 206   | C23   |
| TCK                | 98  | AD6   |
| TDI                | 94  | AF6   |
| TDO                | 176   | D12   |
| TMS                | 96  | AE6   |
| $V_{CCINT}$ 5V     | 11, 59, 124, 153, 204   | J23, V24, AF23, AC15, AF15, AD11, AD5, Y3, T1, J3, G4, D5, D10, B13, D17, C22, H24  |
| $V_{CCIO}$ 3.3V/5V | 1, 26, 53, 65, 79, 92, 105, 132, 157, 172, 181, 184                                 | A10, A17, B2, B25, D7, D13, D19, G23, H4, K1, K26, N23, P4, U1, U26, W23, Y4, AC8, AC14, AC20, AE25, AF10, AF17   |
| GND                | 2, 13, 24, 27, 42, 52, 68, 81, 93, 104, 108, 129, 130, 141, 156, 163, 177, 190, 207 | A1, A2, A5, A8, A14, A19, A22, A25, A26, B1, B26, C7, C9, C13, C18, D24, E1, E26, H1, H26, K4, N1, N24, P3, P26, V23, W1, W4, W26, AB1, AB4, AB26, AC9, AD10, AD14, AD15, AD20, AE1, AE26, AF1, AF2, AF5, AF8, AF13, AF19, AF22, AF25, AF26   |
| No Connects        | -   | A18, A23, A24, B4, B8, B10, B23, C1, C2, C3, C4, C5, C8, C11, C24, C25, D1, D3, D4, D14, D16, D21, D23, D25, E3, E4, F3, F23, G25, J2, J24, J26, K2, L4, L23, P2, T3, T4, T24, U25, V25, W3, W24, Y2, AB3, AB23, AC2, AC4, AC6, AC11, AC16, AC17, AC21, AC23, AC24, AC25, AD16, AD21, AD24, AD26, AE2, AE4, AE10, AE15, AF3, AF4, AF9, AF20 |

## Device Part Marking and Ordering Combination Information

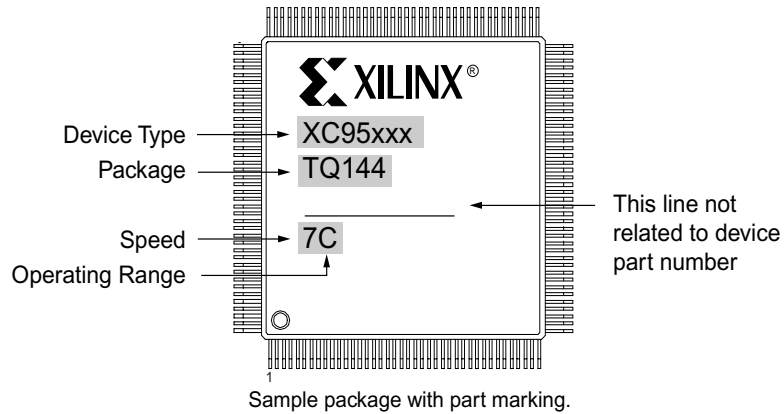

| Device Ordering and Part Marking Number | Speed (pin-to-pin delay) | Pkg. Symbol | No. of Pins | Package Type                    | Operating Range <sup>(1)</sup> |
|---|--------------------------|-------------|-------------|---------------------------------|--------------------------------|
| XC95288-10HQ208C                        | 10 ns                    | HQ208       | 208-pin     | Heat Sink Quad Flat Pack (HQFP) | C                              |
| XC95288-10BG352C                        | 10 ns                    | BG352       | 352-ball    | Ball Grid Array (BGA)           | C                              |
| XC95288-15HQ208C                        | 15 ns                    | HQ208       | 208-pin     | Heat Sink Quad Flat Pack (HQFP) | C                              |
| XC95288-15BG352C                        | 15 ns                    | BG352       | 352-ball    | Ball Grid Array (BGA)           | C                              |
| XC95288-15HQ208I                        | 15 ns                    | HQ208       | 208-pin     | Heat Sink Quad Flat Pack (HQFP) | I                              |
| XC95288-15BG352I                        | 15 ns                    | BG352       | 352-ball    | Ball Grid Array (BGA)           | I                              |
| XC95288-20HQ208C                        | 20 ns                    | HQ208       | 208-pin     | Heat Sink Quad Flat Pack (HQFP) | C                              |
| XC95288-20BG352C                        | 20 ns                    | BG352       | 352-ball    | Ball Grid Array (BGA)           | C                              |
| XC95288-20HQ208I                        | 20 ns                    | HQ208       | 208-pin     | Heat Sink Quad Flat Pack (HQFP) | I                              |
| XC95288-20BG352I                        | 20 ns                    | BG352       | 352-ball    | Ball Grid Array (BGA)           | I                              |

**Notes:**

1. C = Commercial: T<sub>A</sub> = 0° to +70°C; I = Industrial: T<sub>A</sub> = -40° to +85°C

## Revision History

The following table shows the revision history for this document.

| Date     | Version | Revision   |
|----------|---------|--|
| 12/04/98 | 3.1     | Update AC characteristics and internal parameters.                               |
| 06/18/03 | 4.0     | Updated format.  |
| 08/21/03 | 4.1     | Updated Package Device Marking Pin 1 orientation.                                |
| 04/15/05 | 4.2     | Added asynchronous preset/reset pulse width specification (T <sub>APRPW</sub> ). |