

SN74BCT29864B 9-BIT BUS TRANSCEIVER WITH 3-STATE OUTPUTS

SCBS010A – NOVEMBER 1988 – REVISED NOVEMBER 1993

- BiCMOS Design Substantially Reduces Standby Current
- Functionally Equivalent to ALS29864 and AMD Am29864A
- Power-Up High-Impedance State
- ESD Protection Exceeds 2000 V Per MIL-STD-883C, Method 3015
- Package Options Include Plastic Small-Outline (DW) Packages and Standard Plastic 300-mil DIPs (NT)

description

This 9-bit transceiver is designed for asynchronous communication between data buses. The control-function implementation allows for maximum flexibility in timing.

The device allows data transmission from the A bus to the B bus or from the B bus to the A bus, depending upon the logic levels at the output-enable (\overline{OEBA} and \overline{OEAB}) inputs.

The outputs are in the high-impedance state during power-up and power-down conditions. The outputs remain in the high-impedance state while the device is powered-down.

The SN74BCT29864B is characterized for operation from 0°C to 70°C.

DW OR NT PACKAGE
(TOP VIEW)

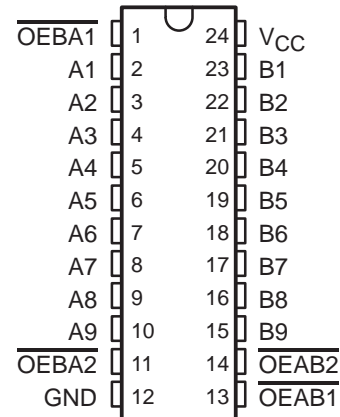

FUNCTION TABLE

INPUTS				OPERATION
$\overline{OEAB1}$	$\overline{OEAB2}$	$\overline{OEBA1}$	$\overline{OEBA2}$	
L	L	L	L	Latch A and B
L	L	H	X	A to B
L	L	X	H	
H	X	L	L	\overline{B} to A
X	H	L	L	
H	X	H	X	Isolation
H	X	X	H	
X	H	X	H	
X	H	H	X	

SN74BCT29864B

9-BIT BUS TRANSCEIVER WITH 3-STATE OUTPUTS

SCBS010A – NOVEMBER 1988 – REVISED NOVEMBER 1993

logic symbol†

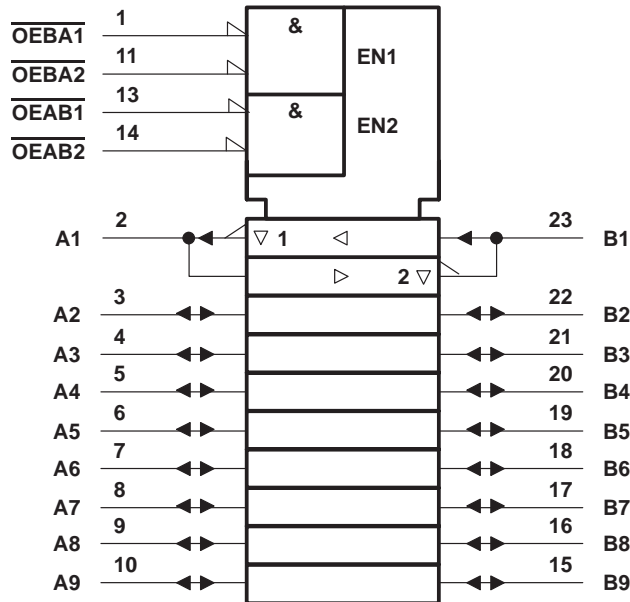

logic diagram (positive logic)

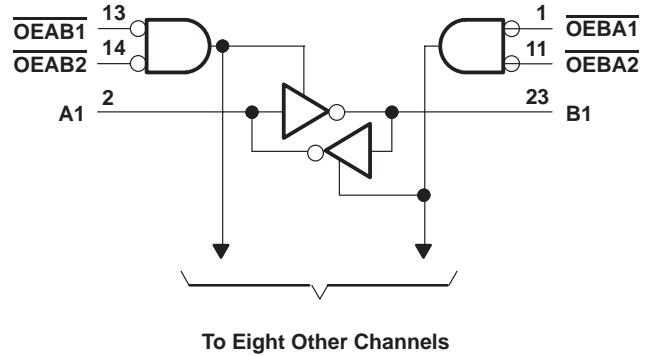

† This symbol is in accordance with ANSI/IEEE Std 91-1984 and IEC Publication 617-12.

absolute maximum ratings over operating free-air temperature range (unless otherwise noted)‡

Supply voltage range, V_{CC}	–0.5 V to 7 V
Input voltage range (I/O ports) (see Note 1)	–0.5 V to 5.5 V
Input voltage range (excluding I/O ports) (see Note 1)	–0.5 V to 7 V
Voltage range applied to any output in the high state	–0.5 V to V_{CC}
Input clamp current	–30 mA
Current into any output in the low state	96 mA
Operating free-air temperature range	0°C to 70°C
Storage temperature range	–65°C to 150°C

‡ Stresses beyond those listed under “absolute maximum ratings” may cause permanent damage to the device. These are stress ratings only, and functional operation of the device at these or any other conditions beyond those indicated under “recommended operating conditions” is not implied. Exposure to absolute-maximum-rated conditions for extended periods may affect device reliability.

NOTE 1: The negative voltage rating may be exceeded if the input current rating is observed.

recommended operating conditions

		MIN	NOM	MAX	UNIT
V_{CC}	Supply voltage	4.5	5	5.5	V
V_{IH}	High-level input voltage	2			V
V_{IL}	Low-level input voltage			0.8	V
I_{IK}	Input clamp current			–18	mA
I_{OH}	High-level output current			–24	mA
I_{OL}	Low-level output current			48	mA
T_A	Operating free-air temperature	0		70	°C

SN74BCT29864B

9-BIT BUS TRANSCEIVER WITH 3-STATE OUTPUTS

SCBS010A – NOVEMBER 1988 – REVISED NOVEMBER 1993

electrical characteristics over recommended operating free-air temperature range (unless otherwise noted)

PARAMETER		TEST CONDITIONS		MIN	TYP†	MAX	UNIT
V_{IK}		$V_{CC} = 4.5\text{ V}$, $I_I = -18\text{ mA}$				-1.2	V
V_{OH}		$V_{CC} = 4.5\text{ V}$	$I_{OH} = -15\text{ mA}$	2.4	3.3		V
			$I_{OH} = -24\text{ mA}$	2	3.1		
V_{OL}		$V_{CC} = 4.75\text{ V}$,	$I_{OH} = -3\text{ mA}$	2.7			
V_{OL}		$V_{CC} = 4.5\text{ V}$	$I_{OL} = 48\text{ mA}$	0.35	0.5		V
I_I		$V_{CC} = 5.5\text{ V}$,	$V_I = 5.5\text{ V}$			0.1	mA
I_{IH}	Control inputs	$V_{CC} = 5.5\text{ V}$,	$V_I = 2.7\text{ V}$			20	μA
	A or B port‡					20	
I_{IL}	Control inputs	$V_{CC} = 5.5\text{ V}$,	$V_I = 0.5\text{ V}$			-0.2	mA
	A or B port‡					-0.2	
$I_{O(off)}^{\S}$		$V_{CC} = 0$,	$V_O = 2.7\text{ V}$			0.1	mA
I_{OS}^{\parallel}		$V_{CC} = 5.5\text{ V}$,	$V_O = 0$	-75		-250	mA
I_{CC}		$V_{CC} = 5.5\text{ V}$	Outputs high		18	30	mA
			Outputs low		30	45	
			Outputs disabled		6.5	12	
C_i		$V_{CC} = 5\text{ V}$,	$V_I = 0.5\text{ V}$ or 2.5 V		6		pF
C_{io}		$V_{CC} = 5\text{ V}$,	$V_I = 0.5\text{ V}$ or 2.5 V		8		pF

† All typical values are at $V_{CC} = 5\text{ V}$, $T_A = 25^\circ\text{C}$.

‡ For I/O ports, the parameters I_{IH} and I_{IL} include the off-state output current.

§ $I_{O(off)}$ = Power-off bus leakage current

¶ Not more than one output should be shorted at a time and duration of the short circuit should not exceed one second.

switching characteristics (see Note 2)

PARAMETER	FROM (INPUT)	TO (OUTPUT)	$V_{CC} = 5\text{ V}$, $C_L = 50\text{ pF}$, $R_1 = 500\ \Omega$, $R_2 = 500\ \Omega$, $T_A = 25^\circ\text{C}$			$V_{CC} = 4.5\text{ V to }5.5\text{ V}$, $C_L = 50\text{ pF}$, $R_1 = 500\ \Omega$, $R_2 = 500\ \Omega$, $T_A = \text{MIN to MAX}^{\#}$		UNIT
			MIN	TYP	MAX	MIN	MAX	
t_{PLH}	A or B	B or A	1	3.5	5.3	1	6.1	ns
t_{PHL}			0.5	2.3	4.6	0.5	4.8	
t_{PZH}	\overline{OEAB} or \overline{OEBA}	A or B	2.3	5	7.2	2.3	8.4	ns
t_{PZL}			4.3	7.3	10.6	4.3	12.5	
t_{PHZ}	\overline{OEAB} or \overline{OEBA}	A or B	2.3	4.6	7.6	2.3	8.4	ns
t_{PLZ}			2	4	7	2	8.2	

For conditions shown as MIN or MAX, use the appropriate value specified under recommended operating conditions.

NOTE 2: Load circuits and voltage waveforms are shown in Section 1.

PACKAGING INFORMATION

Orderable Device	Status ⁽¹⁾	Package Type	Package Drawing	Pins	Package Qty	Eco Plan ⁽²⁾	Lead/Ball Finish	MSL Peak Temp ⁽³⁾
SN74BCT29864BDW	ACTIVE	SOIC	DW	24	25	Pb-Free (RoHS)	CU NIPDAU	Level-2-250C-1 YEAR/ Level-1-235C-UNLIM
SN74BCT29864BDWR	ACTIVE	SOIC	DW	24	2000	Pb-Free (RoHS)	CU NIPDAU	Level-2-250C-1 YEAR/ Level-1-235C-UNLIM
SN74BCT29864BNT	ACTIVE	PDIP	NT	24	15	Pb-Free (RoHS)	CU NIPDAU	Level-NC-NC-NC

⁽¹⁾ The marketing status values are defined as follows:

ACTIVE: Product device recommended for new designs.

LIFEBUY: TI has announced that the device will be discontinued, and a lifetime-buy period is in effect.

NRND: Not recommended for new designs. Device is in production to support existing customers, but TI does not recommend using this part in a new design.

PREVIEW: Device has been announced but is not in production. Samples may or may not be available.

OBsolete: TI has discontinued the production of the device.

⁽²⁾ Eco Plan - May not be currently available - please check <http://www.ti.com/productcontent> for the latest availability information and additional product content details.

None: Not yet available Lead (Pb-Free).

Pb-Free (RoHS): TI's terms "Lead-Free" or "Pb-Free" mean semiconductor products that are compatible with the current RoHS requirements for all 6 substances, including the requirement that lead not exceed 0.1% by weight in homogeneous materials. Where designed to be soldered at high temperatures, TI Pb-Free products are suitable for use in specified lead-free processes.

Green (RoHS & no Sb/Br): TI defines "Green" to mean "Pb-Free" and in addition, uses package materials that do not contain halogens, including bromine (Br) or antimony (Sb) above 0.1% of total product weight.

⁽³⁾ MSL, Peak Temp. -- The Moisture Sensitivity Level rating according to the JEDEC industry standard classifications, and peak solder temperature.

Important Information and Disclaimer: The information provided on this page represents TI's knowledge and belief as of the date that it is provided. TI bases its knowledge and belief on information provided by third parties, and makes no representation or warranty as to the accuracy of such information. Efforts are underway to better integrate information from third parties. TI has taken and continues to take reasonable steps to provide representative and accurate information but may not have conducted destructive testing or chemical analysis on incoming materials and chemicals. TI and TI suppliers consider certain information to be proprietary, and thus CAS numbers and other limited information may not be available for release.

In no event shall TI's liability arising out of such information exceed the total purchase price of the TI part(s) at issue in this document sold by TI to Customer on an annual basis.

NT (R-PDIP-T**)

PLASTIC DUAL-IN-LINE PACKAGE

24 PINS SHOWN

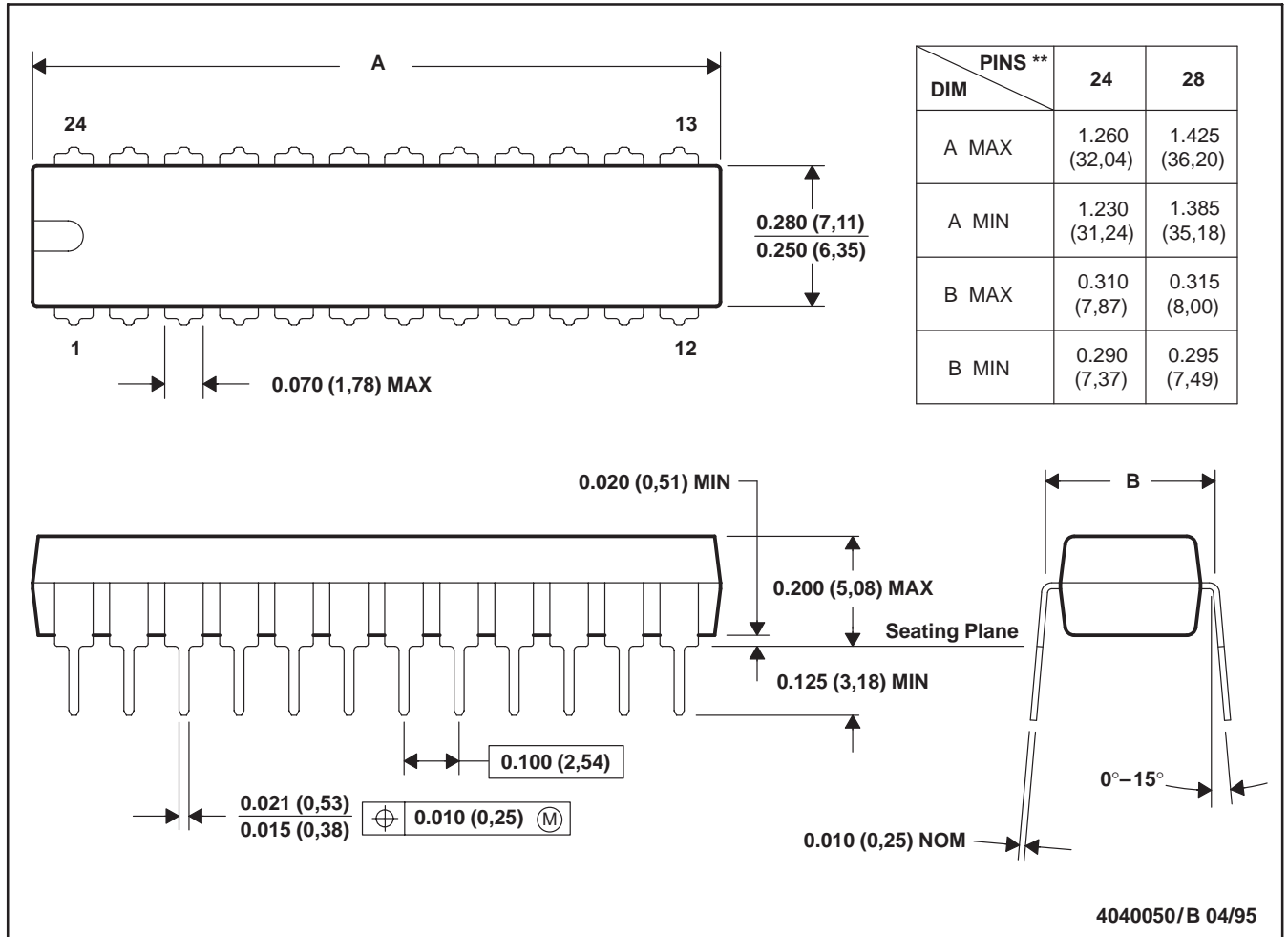

NOTES: A. All linear dimensions are in inches (millimeters).
 B. This drawing is subject to change without notice.

DW (R-PDSO-G24)

PLASTIC SMALL-OUTLINE PACKAGE

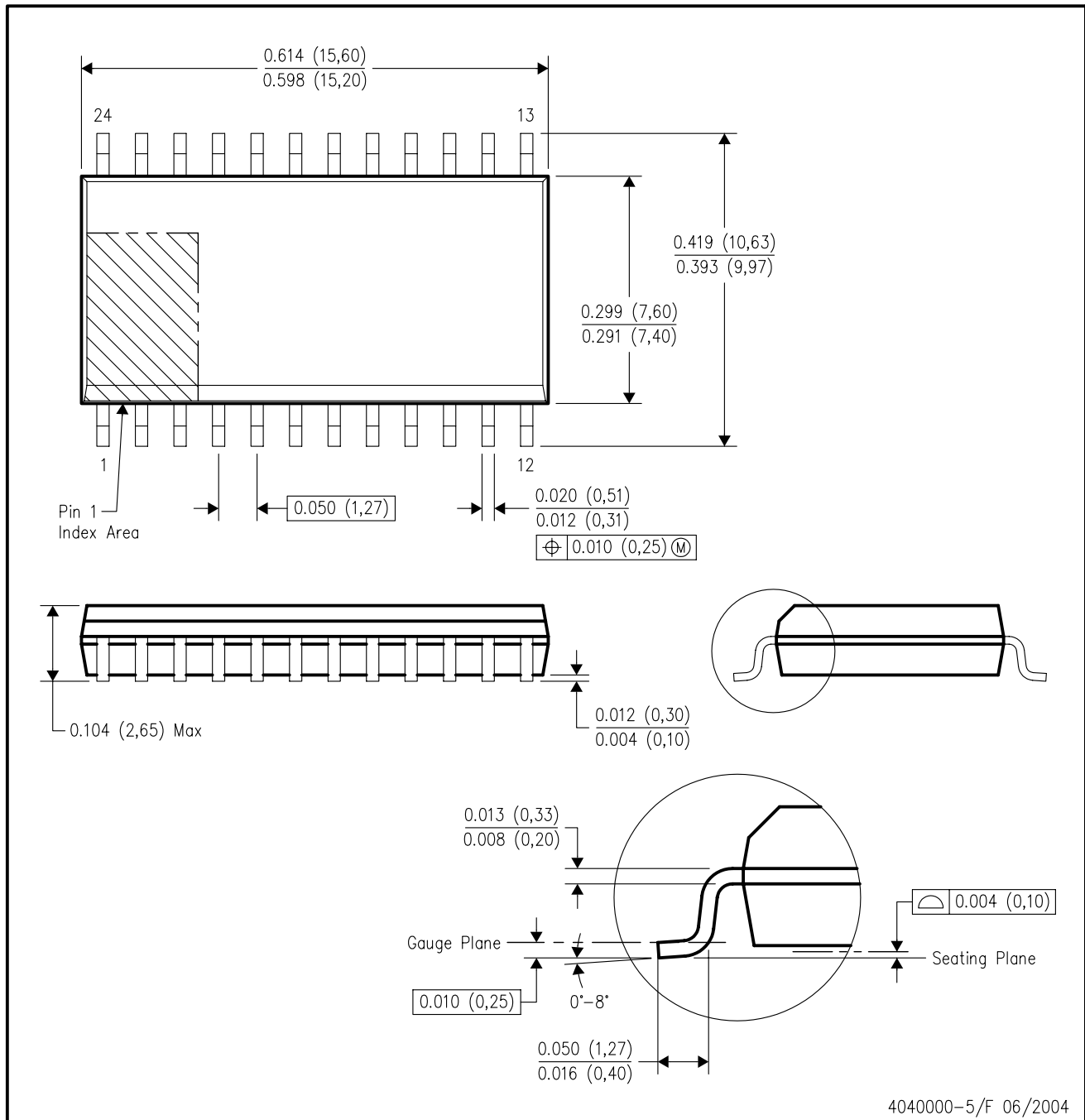

4040000-5/F 06/2004

- NOTES:
- A. All linear dimensions are in inches (millimeters).
 - B. This drawing is subject to change without notice.
 - C. Body dimensions do not include mold flash or protrusion not to exceed 0.006 (0,15).
 - D. Falls within JEDEC MS-013 variation AD.

IMPORTANT NOTICE

Texas Instruments Incorporated and its subsidiaries (TI) reserve the right to make corrections, modifications, enhancements, improvements, and other changes to its products and services at any time and to discontinue any product or service without notice. Customers should obtain the latest relevant information before placing orders and should verify that such information is current and complete. All products are sold subject to TI's terms and conditions of sale supplied at the time of order acknowledgment.

TI warrants performance of its hardware products to the specifications applicable at the time of sale in accordance with TI's standard warranty. Testing and other quality control techniques are used to the extent TI deems necessary to support this warranty. Except where mandated by government requirements, testing of all parameters of each product is not necessarily performed.

TI assumes no liability for applications assistance or customer product design. Customers are responsible for their products and applications using TI components. To minimize the risks associated with customer products and applications, customers should provide adequate design and operating safeguards.

TI does not warrant or represent that any license, either express or implied, is granted under any TI patent right, copyright, mask work right, or other TI intellectual property right relating to any combination, machine, or process in which TI products or services are used. Information published by TI regarding third-party products or services does not constitute a license from TI to use such products or services or a warranty or endorsement thereof. Use of such information may require a license from a third party under the patents or other intellectual property of the third party, or a license from TI under the patents or other intellectual property of TI.

Reproduction of information in TI data books or data sheets is permissible only if reproduction is without alteration and is accompanied by all associated warranties, conditions, limitations, and notices. Reproduction of this information with alteration is an unfair and deceptive business practice. TI is not responsible or liable for such altered documentation.

Resale of TI products or services with statements different from or beyond the parameters stated by TI for that product or service voids all express and any implied warranties for the associated TI product or service and is an unfair and deceptive business practice. TI is not responsible or liable for any such statements.

Following are URLs where you can obtain information on other Texas Instruments products and application solutions:

Products		Applications	
Amplifiers	amplifier.ti.com	Audio	www.ti.com/audio
Data Converters	dataconverter.ti.com	Automotive	www.ti.com/automotive
DSP	dsp.ti.com	Broadband	www.ti.com/broadband
Interface	interface.ti.com	Digital Control	www.ti.com/digitalcontrol
Logic	logic.ti.com	Military	www.ti.com/military
Power Mgmt	power.ti.com	Optical Networking	www.ti.com/opticalnetwork
Microcontrollers	microcontroller.ti.com	Security	www.ti.com/security
		Telephony	www.ti.com/telephony
		Video & Imaging	www.ti.com/video
		Wireless	www.ti.com/wireless

Mailing Address: Texas Instruments
Post Office Box 655303 Dallas, Texas 75265

This datasheet has been download from:

www.datasheetcatalog.com

Datasheets for electronics components.