

TOSHIBA MOS MEMORY PRODUCTS

THM91000AS/AL-70, 80, 10
THM91021AL-70, 80, 10

DESCRIPTION

The THM91000AS/AL is a 1,048,576 words by 9 bits dynamic RAM module which assembled 9 pcs of TC511000AJ on the printed circuit board.

The THM91000AS/AL is optimized for application to the systems which are required high density and large capacity such as main memory of the computers and an image memory systems, and to the others which are requested compact size.

FEATURES

- 1,048,576 words by 9 bits organization
- Fast access time

		THM91000AS/AL, THM91020AL		
		-70	-80	-10
t_{RAC}	\overline{RAS} Access Time	70 ns	80 ns	100 ns
t_{AA}	Column Address Access Time	35 ns	40 ns	50 ns
t_{CAC}	\overline{CAS} Access Time	20 ns	20 ns	25 ns
t_{RC}	Cycle Time	130 ns	150 ns	180 ns
t_{PC}	Fast Page Mode Cycle Time	40 ns	45 ns	55 ns

- Single power supply of $5V \pm 10\%$
- Lower power
 - 3960mW MAX. Operating (THM91000AS/AL-70, THM91020AL-70)
 - 3465mW MAX. Operating (THM91000AS/AL-80, THM91020AL-80)
 - 2970mW MAX. Operating (THM91000AS/AL-10, THM91020AL-10)
 - 49.5mW MAX. Standby
- \overline{CAS} before \overline{RAS} refresh, \overline{RAS} only refresh, Hidden refresh, and Fast Page Mode capability
- All inputs and outputs TTL compatible
- 512 refresh cycles/8ms

PIN CONNECTION

(TOP VIEW) THM91000AS

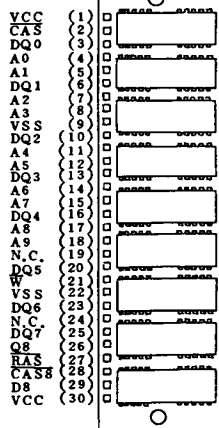

THM91000AL

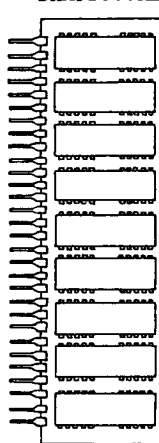

THM91020AL

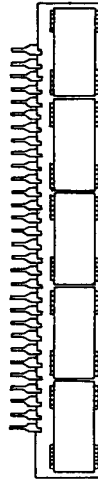

PIN NAMES

A0 ~ A9	Address Inputs
DQ0 ~ DQ7	Data Input/Outputs
D8	Data Input
Q8	Data Output
\overline{CAS}	Column Address Strobe
\overline{RAS}	Row Address Strobe
\overline{W}	Read/Write Input
$\overline{CAS8}$	Column Address Strobe
V_{CC}	Power (+5V)
V_{SS}	Ground
N.C.	No Connection

THM91000AS/AL-70, 80, 10
THM91021AL-70, 80, 10

BLOCK DIAGRAM

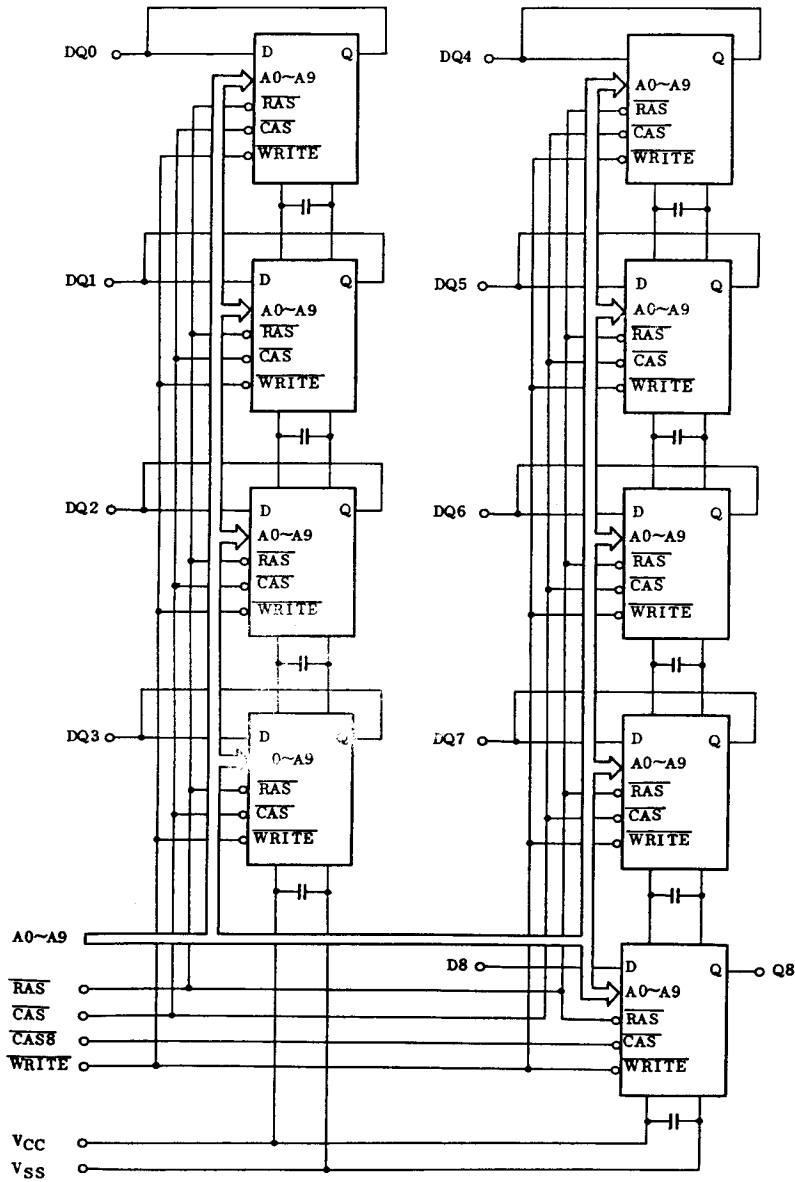

THM91000AS/AL-70, 80, 10
THM91021AL-70, 80, 10

ABSOLUTE MAXIMUM RATINGS

ITEM	SYMBOL	RATING	UNITS	NOTES
Input Voltage	V _{IN}	-1.0~7.0	V	1
Output Voltage	V _{OUT}	-1.0~7.0	V	1
Power Supply Voltage	V _{CC}	-1.0~7.0	V	1
Operating Temperature	T _{OPR}	0~70	°C	1
Storage Temperature	T _{STG}	-55~125	°C	1
Soldering Temperature • Time	T _{SOLDER}	260 • 10	°C • sec	1
Power Dissipation	P _D	5.4	W	1
Short Circuit Output Current	I _{OUT}	50	mA	1

RECOMMENDED DC OPERATING CONDITIONS (Ta=0~70°C)

SYMBOL	PARAMETER	MIN.	TYP.	MAX.	UNIT	NOTES
V _{CC}	Supply Voltage	4.5	5.0	5.5	V	2
V _{IH}	Input High Voltage	2.4		6.5	V	2
V _{IL}	Input Low Voltage	-1.0		0.8	V	2

DC ELECTRICAL CHARACTERISTICS (V_{CC}=5V±10%, Ta=0~70°C)

SYMBOL	PARAMETER	MIN.	MAX.	UNITS	NOTES	
I _{CC1}	OPERATING CURRENT Average Power Supply Operating Current (RAS, CAS, Address Cycling: t _{RC} =t _{RC} MIN.)	THMxxxxxx-70	-	720	mA	3, 4
		THMxxxxxx-80	-	630		
		THMxxxxxx-10	-	540		
I _{CC2}	STANDBY CURRENT Power Supply Standby Current (RAS=CAS=V _{IH})	-	18	mA		
I _{CC3}	RAS ONLY REFRESH CURRENT Average Power Supply Current, RAS Only Mode (RAS Cycling, CAS=V _{IH} : t _{RC} =t _{RC} MIN.)	THMxxxxxx-70	-	720	mA	3
		THMxxxxxx-80	-	630		
		THMxxxxxx-10	-	540		
I _{CC4}	FAST PAGE MODE CURRENT Average Power Supply Current, Fast Page Mode (RAS=V _{IL} , CAS Address Cycling: t _{PC} =t _{PC} MIN.)	THMxxxxxx-70	-	540	mA	3, 4
		THMxxxxxx-80	-	450		
		THMxxxxxx-10	-	360		
I _{CC5}	STANDBY CURRENT Power Supply Standby Current (RAS=CAS=V _{CC} -0.2V)	-	9	mA		
I _{CC6}	CAS BEFORE RAS REFRESH CURRENT Average Power Supply Current, CAS Before RAS Mode (RAS, CAS Cycling: t _{RC} =t _{RC} MIN.)	THMxxxxxx-70	-	720	mA	3
		THMxxxxxx-80	-	630		
		THMxxxxxx-10	-	540		
I _{I(L)}	INPUT LEAKAGE CURRENT Input Leakage Current, any Input (0V ≤ V _{IN} ≤ 6.5V, All Other Pins not under Test=0V)	-90	90	µA		
I _{O(L)}	OUTPUT LEAKAGE CURRENT (DOUT is disabled, 0V ≤ V _{OUT} ≤ 5.5V)	-20	20	µA		
V _{OH}	OUTPUT LEVEL Output "H" Level Voltage (I _{OUT} =5-mA)	2.4	-	V		
V _{OL}	OUTPUT LEVEL Output "L" Level Voltage (I _{OUT} =4.2mA)	-	0.4	V		

THM91000AS/AL-70, 80, 10
THM91021AL-70, 80, 10

ELECTRICAL CHARACTERISTICS AND RECOMMENDED AC OPERATING CONDITIONS

(V_{CC}=5V±10%, T_a=0~70°C) (Notes 5, 6, 7)

SYMBOL	PARAMETER	THM91000AS/AL, THM91020AL						UNIT	NOTES
		-70		-80		-10			
		MIN.	MAX.	MIN.	MAX.	MIN.	MAX.		
t _{RC}	Random Read or Write Cycle Time	130	-	150	-	180	-	ns	
t _{PC}	Fast Page Mode Cycle Time	40	-	45	-	55	-	ns	
t _{RAC}	Access Time from $\overline{\text{RAS}}$	-	70	-	80	-	100	ns	8,13
t _{CAC}	Access Time from $\overline{\text{CAS}}$	-	20	-	20	-	25	ns	8,13
t _{AA}	Access Time from Column Address	-	35	-	40	-	50	ns	8,14
t _{CPA}	Access Time from $\overline{\text{CAS}}$ Precharge	-	35	-	40	-	50	ns	8
t _{CLZ}	$\overline{\text{CAS}}$ to Output in Low-Z	0	-	0	-	0	-	ns	8
t _{OFF}	Output Buffer Turn-off Dealy	0	20	0	20	0	20	ns	9
t _T	Transition Time (Rise and Fall)	3	50	3	50	3	50	ns	7
t _{RP}	$\overline{\text{RAS}}$ Precharge Time	50	-	60	-	70	-	ns	
t _{RAS}	$\overline{\text{RAS}}$ Pulse Width	70	10,000	80	10,000	100	10,000	ns	
t _{RASP}	$\overline{\text{RAS}}$ Pulse Width (Fast Page Mode)	80	100,000	80	100,000	100	100,000	ns	
t _{RSH}	$\overline{\text{RAS}}$ Hold Time	20	-	20	-	25	-	ns	
t _{CSH}	$\overline{\text{CAS}}$ Hold Time	70	-	80	-	100	-	ns	
t _{CAS}	$\overline{\text{CAS}}$ Pulse Width	20	10,000	20	10,000	25	10,000	ns	
t _{RCD}	$\overline{\text{RAS}}$ to $\overline{\text{CAS}}$ Delay Time	20	50	20	60	25	75	ns	13
t _{RAD}	$\overline{\text{RAS}}$ to Column Address Delay Time	15	35	15	40	20	50	ns	14
t _{CRP}	$\overline{\text{CAS}}$ to $\overline{\text{RAS}}$ Precharge Time	5	-	5	-	5	-	ns	
t _{CP}	$\overline{\text{CAS}}$ Precharge Time (Fast Page Mode)	10	-	10	-	10	-	ns	
t _{ASR}	Row Address Set-Up Time	0	-	0	-	0	-	ns	
t _{RAH}	Row Address Hold Time	10	-	10	-	15	-	ns	
t _{ASC}	Column Address Set-Up Time	0	-	0	-	0	-	ns	
t _{CAH}	Column Address Hold Time	15	-	15	-	20	-	ns	
t _{AR}	Column Address Hold Time referenced to $\overline{\text{RAS}}$	55	-	60	-	75	-	ns	
t _{RAL}	Column Address to $\overline{\text{RAS}}$ Lead Time	35	-	40	-	50	-	ns	
t _{RCS}	Read Command Set-Up Time	0	-	0	-	0	-	ns	

THM91000AS/AL-70, 80, 10
THM91021AL-70, 80, 10

ELECTRICAL CHARACTERISTICS AND RECOMMENDED AC OPERATING CONDITIONS (Continued)

SYMBOL	PARAMETER	THM91000AS/AL, THM91020AL						UNITS	NOTES
		-70		-80		-10			
		MIN.	MAX.	MIN.	MAX.	MIN.	MAX.		
t _{TRCH}	Read Command Hold Time	0	-	0	-	0	-	ns	10
t _{TRRH}	Read Command Hold Time referenced to RAS	0	-	0	-	0	-	ns	10
t _{WCH}	Write Command Hold Time	15	-	15	-	20	-	ns	
t _{WCR}	Write Command Hold Time referenced to RAS	55	-	60	-	75	-	ns	
t _{WP}	Write Command Pulse Width	15	-	15	-	20	-	ns	
t _{RWL}	Write Command to $\overline{\text{RAS}}$ Lead Time	20	-	20	-	25	-	ns	
t _{CWL}	Write Command to $\overline{\text{CAS}}$ Lead Time	20	-	20	-	25	-	ns	
t _{DS}	Data Set-Up Time	0	-	0	-	0	-	ns	11
t _{DH}	Data Hold Time	15	-	15	-	20	-	ns	11
t _{DHR}	Data Hold Time referenced to RAS	55	-	60	-	75	-	ns	
t _{REF}	Refresh Period	-	8	-	8	-	8	ms	
t _{WCS}	Write Command Set-Up Time	0	-	0	-	0	-	ns	12
t _{CSR}	$\overline{\text{CAS}}$ Set-Up Time ($\overline{\text{CAS}}$ before RAS Cycle)	10	-	10	-	10	-	ns	
t _{CHR}	$\overline{\text{CAS}}$ Hold Time ($\overline{\text{CAS}}$ before RAS Cycle)	30	-	30	-	30	-	ns	
t _{RPC}	RAS to $\overline{\text{CAS}}$ Precharge Time	0	-	0	-	0	-	ns	
t _{CPT}	$\overline{\text{CAS}}$ Precharge Time ($\overline{\text{CAS}}$ before RAS Counter Test Cycle)	40	-	40	-	50	-	ns	
t _{CPN}	$\overline{\text{CAS}}$ Precharge Time	10	-	10	-	15	-	ns	

CAPACITANCE ($V_{CC}=5V\pm 10\%$, $f=1\text{MHz}$, $T_a=0\sim 70^\circ\text{C}$)

SYMBOL	PARAMETER	MIN.	MAX.	UNIT
C _{I1}	Input Capacitance (A0 ~ A9, $\overline{\text{W}}$, $\overline{\text{CAS}}$, $\overline{\text{RAS}}$)	-	60	pF
C _{I2}	Input Capacitance (D8, $\overline{\text{CAS8}}$)	-	7	pF
C _{DQ}	I/O Capacitance (DQ0 ~ DQ7)	-	15	pF
C _Q	Output Capacitance (Q8)	-	10	pF

THM91000AS/AL-70, 80, 10

THM91021AL-70, 80, 10

NOTES:

1. Stresses greater than those listed under "Absolute Maximum Ratings" may cause permanent damage to the device.
2. All voltages are referenced to V_{SS} .
3. I_{CC1} , I_{CC3} , I_{CC4} , I_{CC6} depend on cycle rate.
4. I_{CC1} , I_{CC4} depend on output loading. Specified values are obtained with the output open.
5. An initial pause of 200 μ s is required after power-up followed by 8 \overline{RAS} cycles before proper device operation is achieved. In case of using internal refresh counter, a minimum of 8 CAS before \overline{RAS} initialization cycles instead of 8 \overline{RAS} cycles are required.
6. AC measurements assume $t_T=5$ ns.
7. $V_{IH}(\text{min.})$ and $V_{IL}(\text{max.})$ are reference levels for measuring timing of input signals. Also, transition times are measured between V_{IH} and V_{IL} .
8. Measured with a load equivalent to 2 TTL loads and 100pF.
9. $t_{OFF}(\text{max.})$ defines the time at which the output achieves the open circuit condition and is not referenced to output voltage levels.
10. Either t_{RCH} or t_{RRH} must be satisfied for a read cycle.
11. These parameters are referenced to \overline{CAS} leading edge.
12. t_{WCS} is not restrictive operating parameters. This is included the data sheet as electrical characteristics only. If $t_{WCS} \geq t_{WCS}(\text{min.})$, the cycle is an early write cycle and data out pin will remain open circuit (high impedance).
13. Operation within the $t_{RCD}(\text{max.})$ limit insures that $t_{RAC}(\text{max.})$ can be met. $t_{RCD}(\text{max.})$ is specified as a reference point only: If t_{RCD} is greater than the specified $t_{RCD}(\text{max.})$ limit, then access time is controlled by t_{CAC} .
14. Operation within the $t_{RAD}(\text{max.})$ limit insures that $t_{RAC}(\text{max.})$ can be met. $t_{RAD}(\text{max.})$ is specified as a reference point only: If t_{RAD} is greater than the specified $t_{RAD}(\text{max.})$ limit, then access time is controlled by t_{AA} .

THM91000AS/AL-70, 80, 10
THM91021AL-70, 80, 10

READ CYCLE

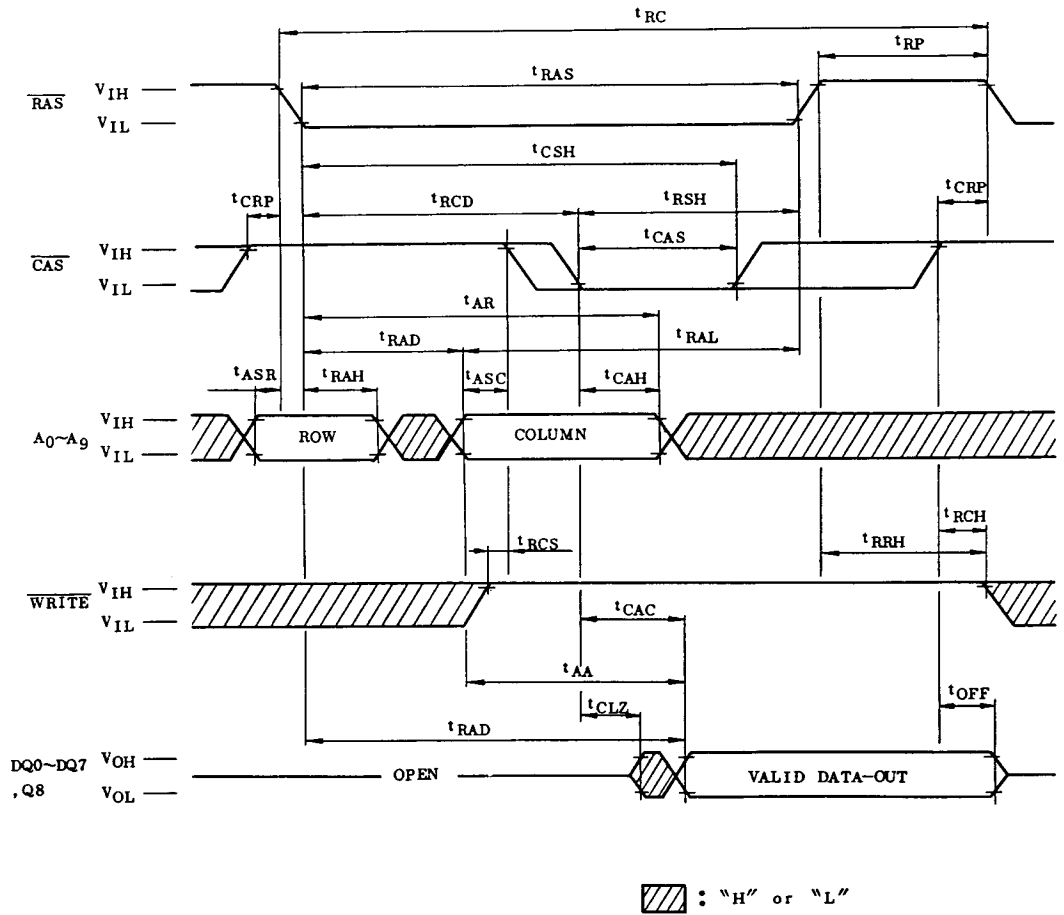

THM91000AS/AL-70, 80, 10

THM91021AL-70, 80, 10

EARLY WRITE CYCLE

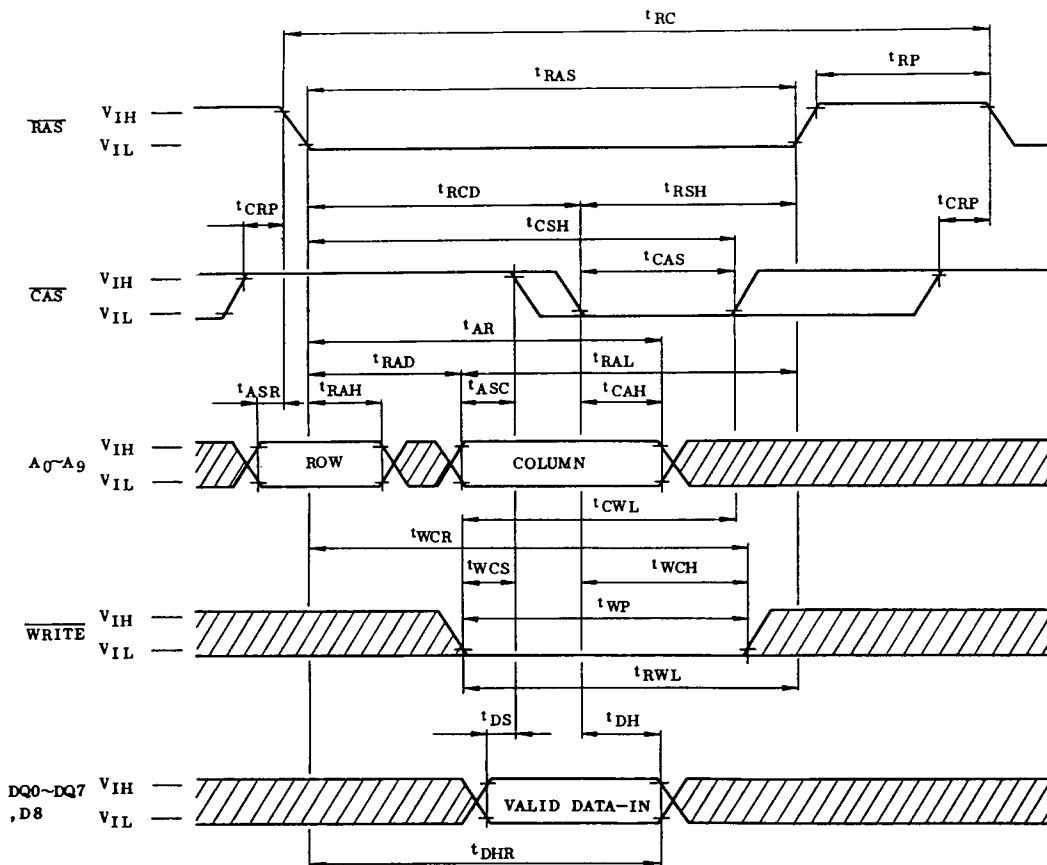

 : "H" or "L"

FAST PAGE MODE READ CYCLE

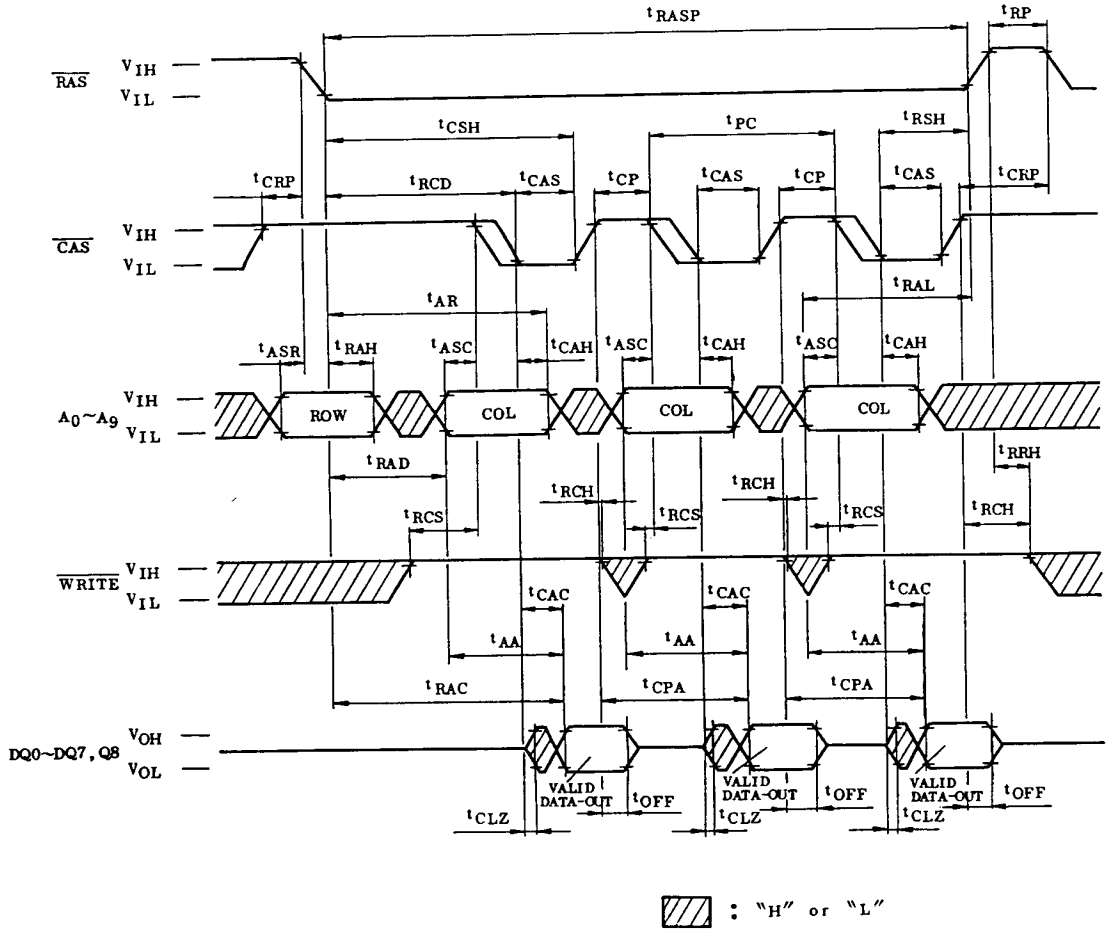

THM91000AS/AL-70, 80, 10
THM91021AL-70, 80, 10

FAST PAGE MODE WRITE CYCLE (EARLY WRITE)

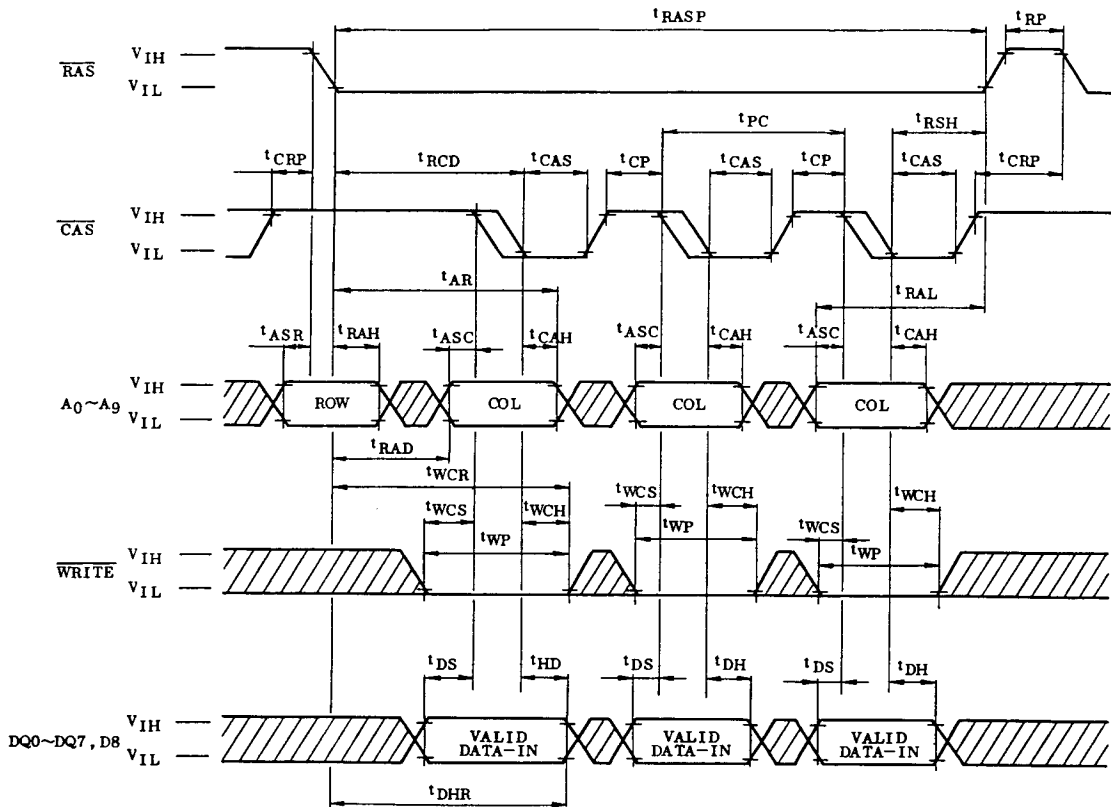

▨ : "H" or "L"

THM91000AS/AL-70, 80, 10
THM91021AL-70, 80, 10

RAS ONLY REFRESH CYCLE

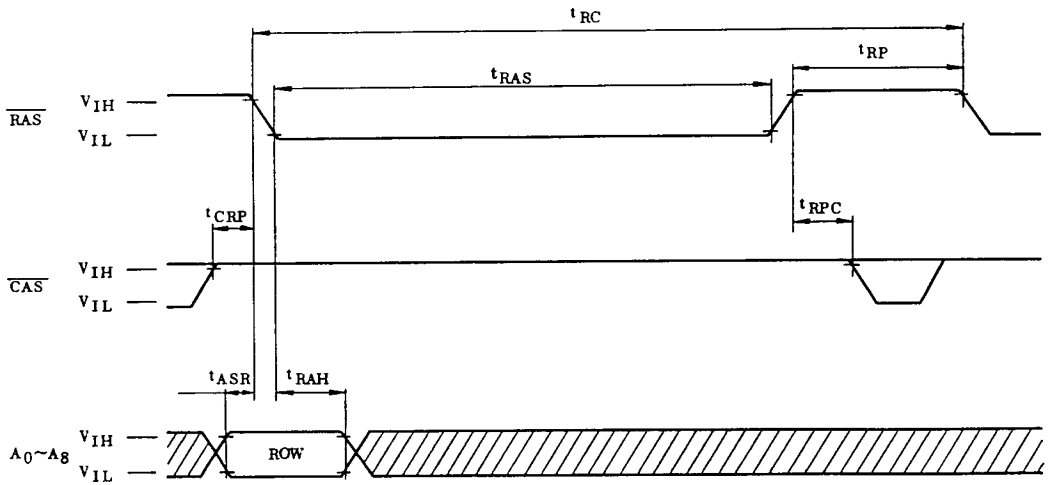

 : "H" or "L"

Note: WRITE="H" or "L", A9="H" or "L"

THM91000AS/AL-70, 80, 10
THM91021AL-70, 80, 10

CAS BEFORE RAS REFRESH CYCLE

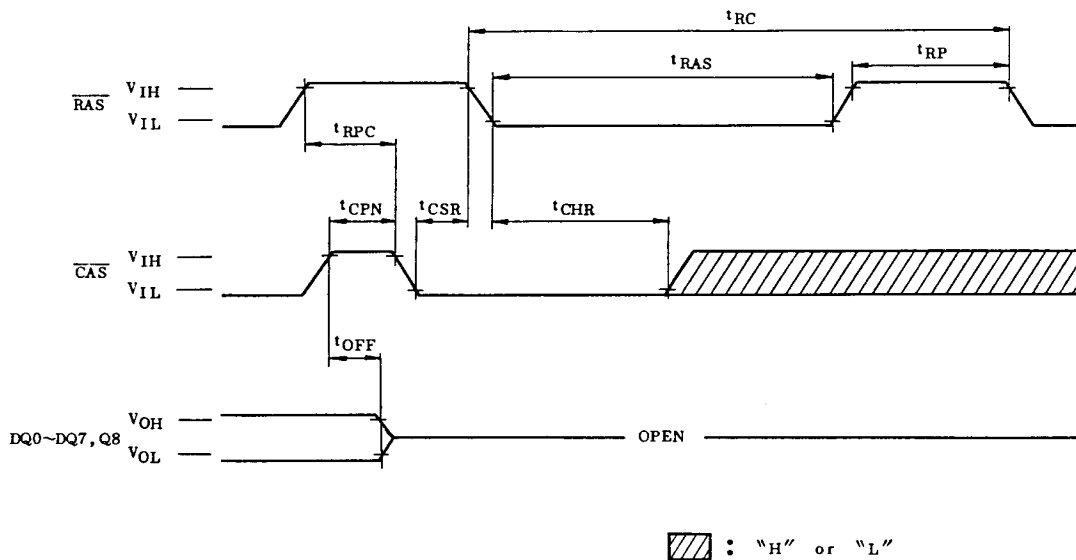

Note: \overline{WRITE} ="H" or "L", $A0 \sim A9$ ="H" or "L"

HIDDEN REFRESH CYCLE (READ)

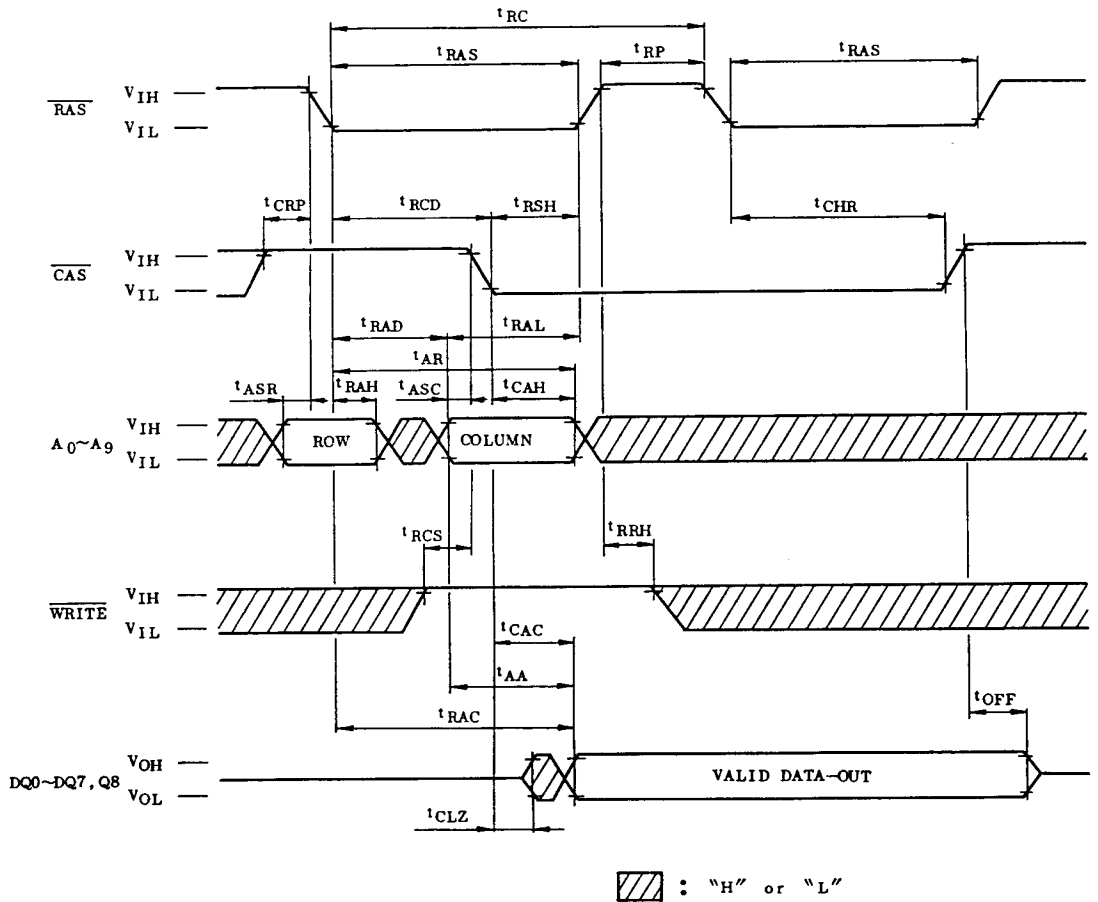

THM91000AS/AL-70, 80, 10
THM91021AL-70, 80, 10

HIDDEN REFRESH CYCLE (WRITE)

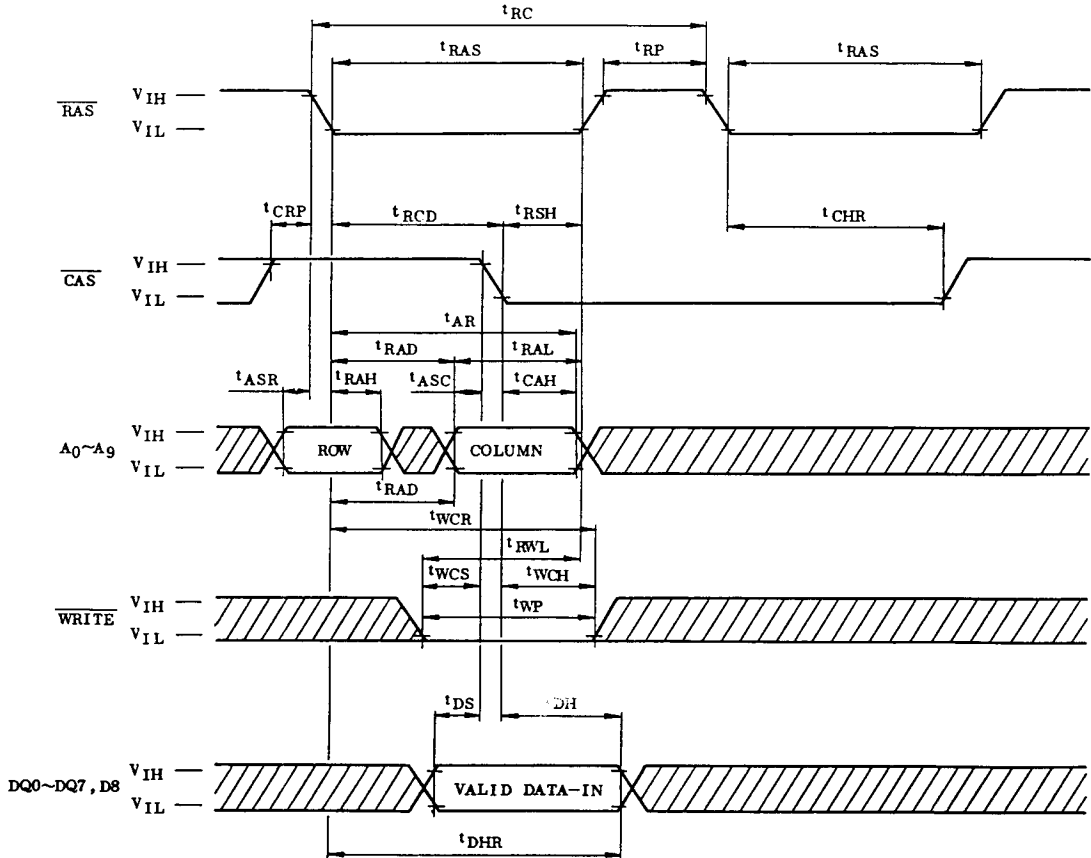

 : "H" or "L"

CAS BEFORE RAS REFRESH COUNTER TEST CYCLE

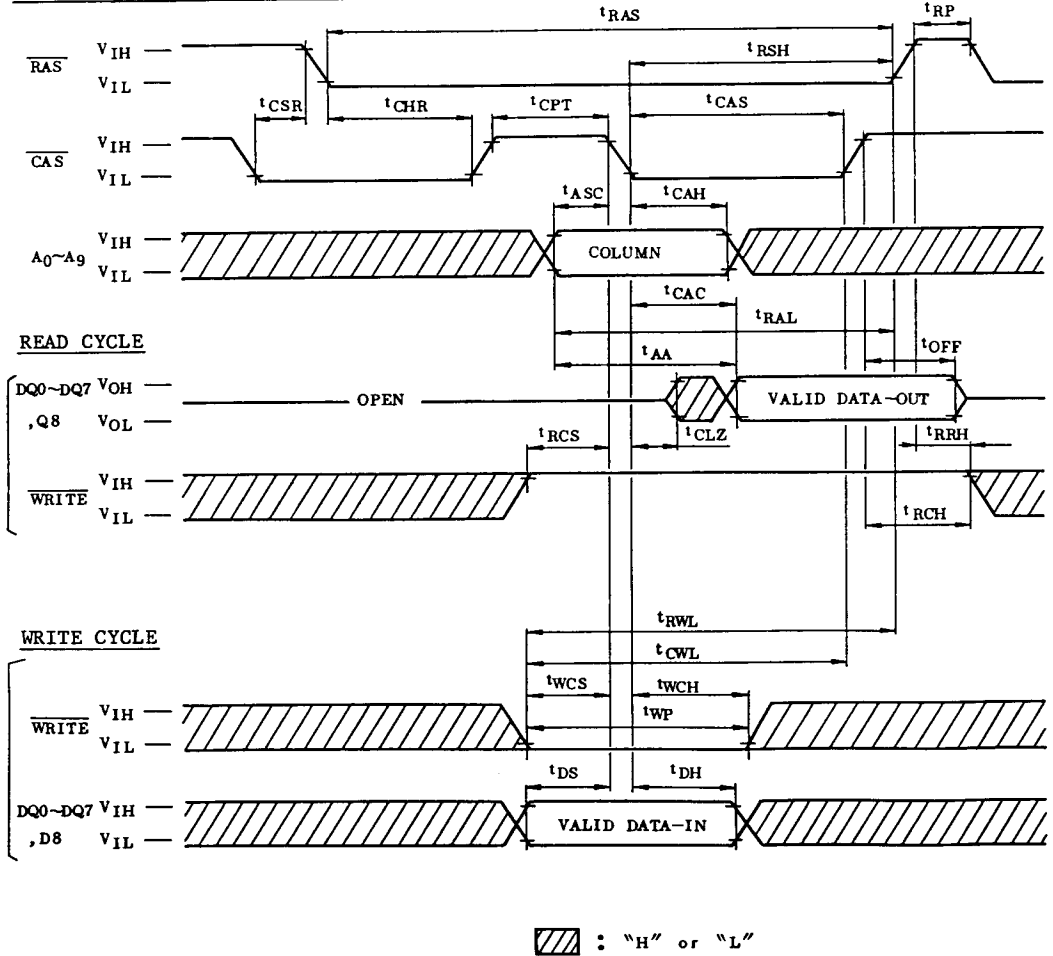

THM91000AS/AL-70, 80, 10
THM91021AL-70, 80, 10

OUTLINE DRAWINGS

• THM91000AS

Unit in mm

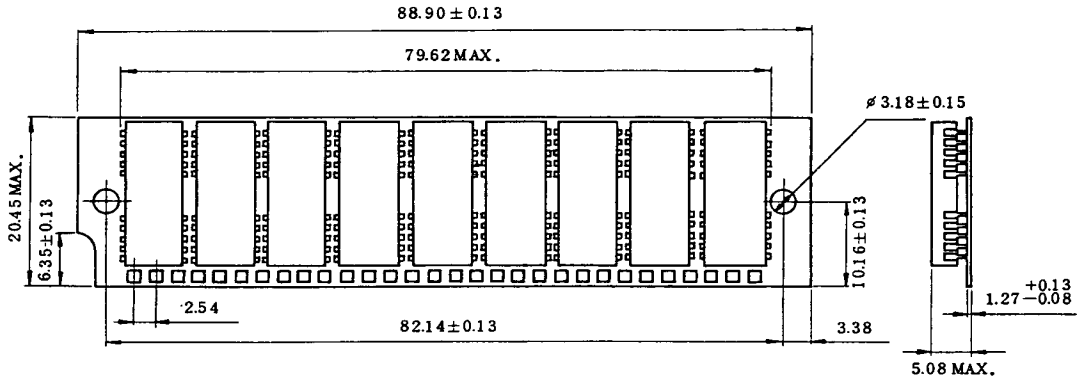

• THM91000AL

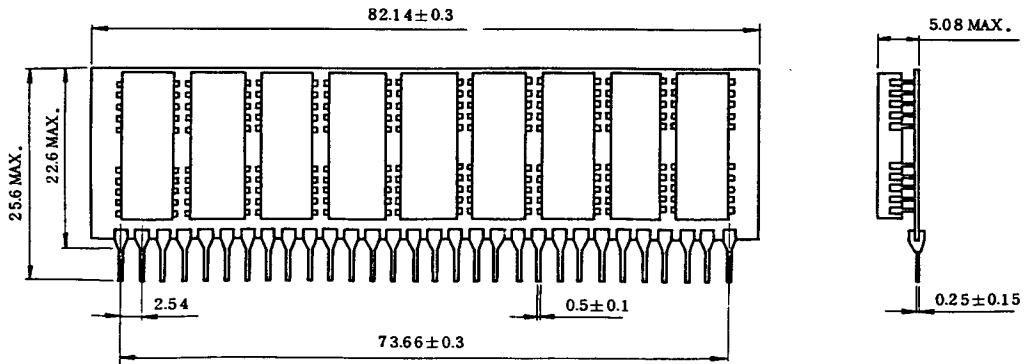

THM91000AS/AL-70, 80, 10
THM91021AL-70, 80, 10

OUTLINE DRAWINGS

• THM91020AL

Unit in mm

