

Dual timer

NE/SA/SE556/NE556-1

DESCRIPTION

Both the 556 and 556-1 Dual Monolithic timing circuits are highly stable controllers capable of producing accurate time delays or oscillation. The 556 and 556-1 are a dual 555. Timing is provided by an external resistor and capacitor for each timing function. The two timers operate independently of each other, sharing only V_{CC} and ground. The circuits may be triggered and reset on falling waveforms. The output structures may sink or source 200mA.

FEATURES

- Turn-off time less than 2μs (556-1)
- Maximum operating frequency >500kHz (556-1)
- Timing from microseconds to hours
- Replaces two 555 timers
- Operates in both astable and monostable modes
- High output current
- Adjustable duty cycle
- TTL compatible
- Temperature stability of 0.005%/°C
- SE556-1 compliant to MIL-STD or JAN

APPLICATIONS

- Precision timing
- Sequential timing
- Pulse shaping

PIN CONFIGURATION

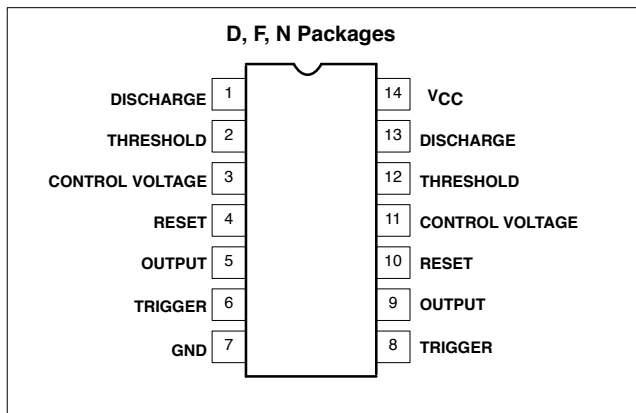

- Pulse generator
- Missing pulse detector
- Tone burst generator
- Pulse width modulation
- Time delay generator
- Frequency division
- Touch-Tone® encoder
- Industrial controls
- Pulse position modulation
- Appliance timing
- Traffic light control

BLOCK DIAGRAM

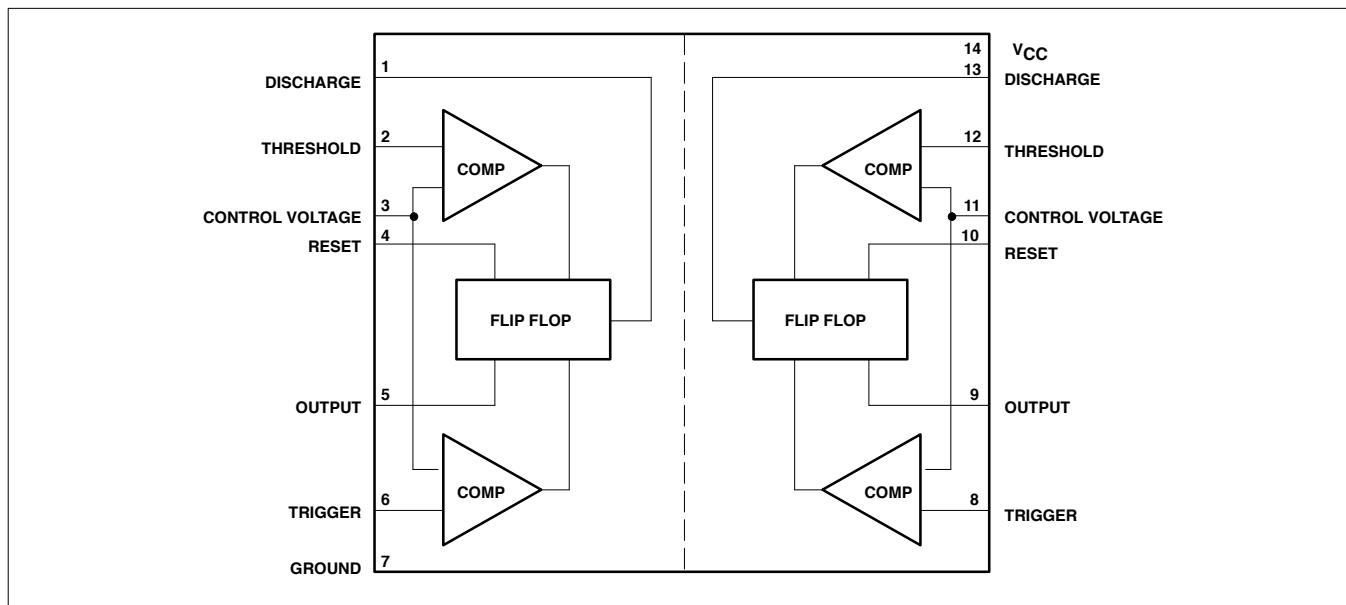

® Touch-Tone is a registered trademark of AT&T

Dual timer

NE/SA/SE556/NE556-1

EQUIVALENT SCHEMATIC (Shown for one circuit only)

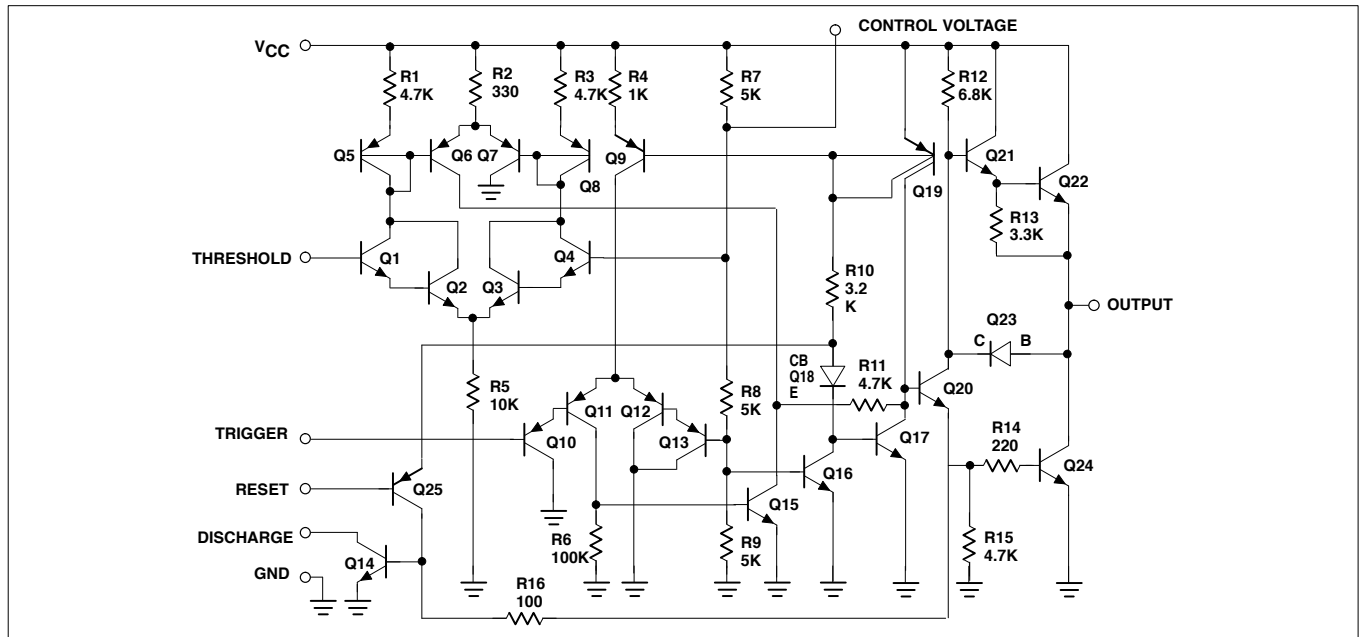

ORDERING INFORMATION

DESCRIPTION	TEMPERATURE RANGE	ORDER CODE	DWG #
14-Pin Plastic Small Outline (SO) Package	0 to +70°C	NE556D	0175D
14-Pin Ceramic Dual In-Line Package (CERDIP)	0 to +70°C	NE556F	0581B
14-Pin Plastic Dual In-Line Package (DIP)	0 to +70°C	NE556N	0405B
14-Pin Ceramic Dual In-Line Package (CERDIP)	0 to +70°C	NE556-1F	0581B
14-Pin Plastic Dual In-Line Package (DIP)	0 to +70°C	NE556-1N	0405B
14-Pin Plastic Dual In-Line Package (DIP)	-40°C to +85°C	SA556N	0405B
14-Pin Ceramic Dual In-Line Package (CERDIP)	-55°C to +125°C	SE556F	0581B
14-Pin Plastic Dual In-Line Package (DIP)	-55°C to +125°C	SE556N	0405B

ABSOLUTE MAXIMUM RATINGS

SYMBOL	PARAMETER	RATING	UNIT
V _{CC}	Supply voltage		
	NE/SA556, NE556-1	+16	V
	SE556	+18	V
P _D	Maximum allowable power dissipation ¹	800	mW
T _A	Operating temperature range		
	NE556-1, NE556	0 to +70	°C
	SA556	-40 to +85	°C
	SE556	-55 to +125	°C
T _{STG}	Storage temperature range	-65 to +150	°C
T _{SOLD}	Lead soldering temperature (10sec max)	+300	°C

NOTES:

- The junction temperature must be kept below 125°C for the D package and below 150°C for the N and F packages. At ambient temperatures above 25°C, where this limit would be exceeded, the Maximum Allowable Power Dissipation must be derated by the following:
 D package 115°C/W
 N package 80°C/W
 F package 100°C/W

Dual timer

NE/SA/SE556/NE556-1

ELECTRICAL CHARACTERISTICST_A=25°C, V_{CC}=+5V to +15V, unless otherwise specified.

SYMBOL	PARAMETER	TEST CONDITIONS	SE556			NE/SA556 NE556-1			UNIT
			Min	Typ	Max	Min	Typ	Max	
V _{CC}	Supply voltage		4.5		18	4.5		16	V
I _{CC}	Supply current (low state) ¹	V _{CC} =5V, R _L =∞		6	10		6	12	mA
		V _{CC} =15V, R _L =∞		20	24		20	30	mA
t _M	Timing error (monostable)	R _A =2kΩ to 100kΩ							
Δt _M /ΔT	Initial accuracy ²	C=0.1μF		0.5	2.0		0.75	3.0	%
Δt _M /ΔV _S	Drift with temperature	T=1.1 RC		30	100		50	150	ppm/°C
	Drift with supply voltage			0.05	0.2		0.1	0.5	%/V
t _A	Timing error (astable)	R _A , R _B =1kΩ to 100kΩ							
Δt _A /ΔT	Initial accuracy ²	C=0.μF		4	6		5	13	%
Δt _A /ΔV _S	Drift with temperature	V _{CC} =15V		400	500		400	500	ppm/°C
	Drift with supply voltage			0.15	0.6		0.3	1	%/V
V _C	Control voltage level	V _{CC} =15V	9.6	10.0	10.4	9.0	10.0	11.0	V
		V _{CC} =5V	2.9	3.33	3.8	2.6	3.33	4.0	
V _{TH}	Threshold voltage	V _{CC} =15V	9.4	10.0	10.6	8.8	10.0	11.2	V
		V _{CC} =5V	2.7	3.33	4.0	2.4	3.33	4.2	V
I _{TH}	Threshold current ³	V _{CC} = 15V, V _{TH} = 10.5V		30	250		30	250	nA
V _{TRIG}	Trigger voltage	V _{CC} =15V	4.8	5.0	5.2	4.5	5.0	5.6	V
		V _{CC} =5V	1.45	1.67	1.9	1.1	1.67	2.2	V
I _{TRIG}	Trigger current	V _{TRIG} =0V		0.5	0.9		0.5	2.0	μA
V _{RESET}	Reset voltage ⁵		0.4	0.7	1.0	0.4	0.7	1.0	V
	Reset current	V _{RESET} =0.4V	0.4	0.1	0.4	0.4	0.1	0.6	mA
I _{RESET}	Reset current	V _{RESET} =0V		0.4	1.0		0.4	1.5	mA
V _{OL}	Output voltage (low)	V _{CC} =15V		0.1	0.15		0.1	0.25	V
		I _{SINK} =10mA		0.4	0.5		0.4	0.75	
	SE556			2.0	2.25				
	NE/SA556 NE556-1	I _{SINK} =100mA					2.0	3.2	
	Output voltage (low)	I _{SINK} =200mA		2.5			2.5	V	
		V _{CC} =5V		0.1	0.2		0.25		
		I _{SINK} =8mA I _{SINK} =5mA	0.05	0.15		0.15	0.25		
V _{OH}	Output voltage (high)	V _{CC} =15V		12.5			12.5	V	
		I _{SOURCE} =200mA	13.0	13.3		12.75	13.3		
		I _{SOURCE} =100mA							
		V _{CC} =5V							
		I _{SOURCE} =100mA	3.0	3.3		2.75	3.3		
t _{OFF}	Turn-off time ⁶ NE556-1	V _{RESET} =V _{CC}		0.5	2.0		0.5		μs
t _R	Rise time of output			100	200		100	300	ns
t _F	Fall time of output			100	200		100	300	ns
	Discharge leakage current			20	100		20	100	nA

Dual timer

NE/SA/SE556/NE556-1

ELECTRICAL CHARACTERISTICS (Continued)

SYMBOL	PARAMETER	TEST CONDITIONS	SE556/556-1			NE/SA556/SE556C NE556-1/SE556-1C			UNIT
			Min	Typ	Max	Min	Typ	Max	
	Matching characteristics ⁴								
	Initial accuracy ²			0.5	1.0		1.0	2.0	%
	Drift with temperature			10			±10		ppm/°C
	Drift with supply voltage			0.1	0.2		0.2	0.5	%/V

NOTES:

- Supply current when output is high is typically 1.0mA less.
- Tested at $V_{CC}=5V$ and $V_{CC}=15V$.
- This will determine maximum value of R_A+R_B . For 15V operation, the max total $R=10M\Omega$, and for 5V operation, the maximum total $R=3.4M\Omega$.
- Matching characteristics refer to the difference between performance characteristics for each timer section in the monostable mode.
- Specified with trigger input high. In order to guarantee reset the voltage at reset pin must be less than or equal to 0.4V. To disable reset function, the voltage at reset pin has to be greater than 1V.
- Time measured from a positive-going input pulse from 0 to 0.4 V_{CC} into the threshold to the drop from high to low of the output. Trigger is tied to threshold.

TYPICAL APPLICATIONS

One feature of the dual timer is that by utilizing both halves it is possible to obtain sequential timing. By connecting the output of the first half to the input of the second half via a $0.001\mu F$ coupling capacitor sequential timing may be obtained. Delay t_1 is determined by the first half and t_2 by the second half delay.

The first half of the timer is started by momentarily connecting Pin 6 to ground. When it is timed out (determined by $1.1R_1C_1$) the second half begins. Its duration is determined by $1.1R_2C_2$.

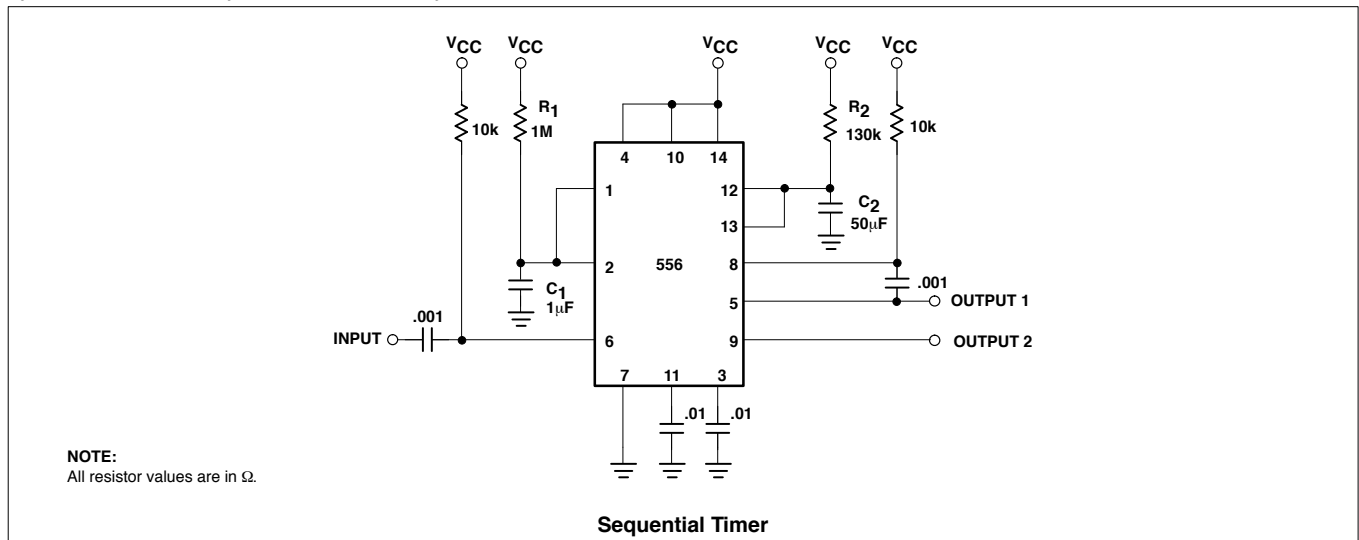

Dual timer

NE/SA/SE556/NE556-1

TYPICAL PERFORMANCE CHARACTERISTICS

