

FPT-34P-M03

<p>34-pin plastic SSOP</p>  <p>(FPT-34P-M03)</p>	Lead pitch	0.65 mm
	Package width × package length	6.10 × 11.00 mm
	Lead shape	Gullwing
	Sealing method	Plastic mold
	Mounting height	1.45 mm MAX
	Code (Reference)	P-SSOP34-6.1×11-0.65

34-pin plastic SSOP (FPT-34P-M03)

Note 1) \*1 : Resin protrusion. (Each side : +0.15 (.006) Max).  
 Note 2) \*2 : These dimensions do not include resin protrusion.  
 Note 3) Pins width and pins thickness include plating thickness.  
 Note 4) Pins width do not include tie bar cutting remainder.

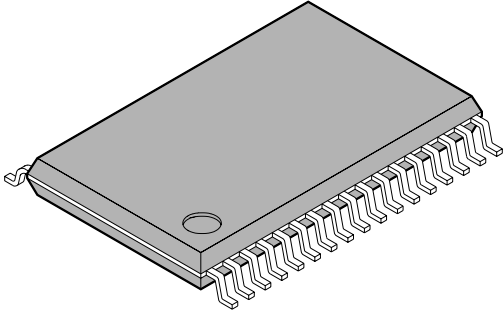
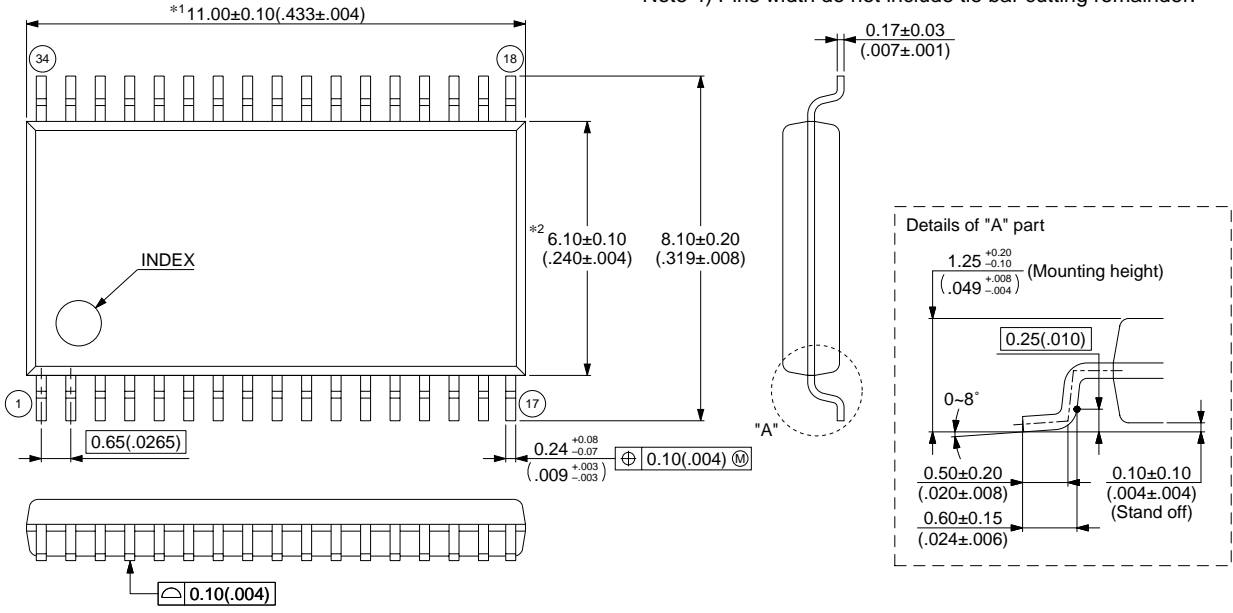

Dimensions in mm (inches).  
 Note: The values in parentheses are reference values

© 2003 FUJITSU LIMITED F34003S-c-2-3

The contents of this document are subject to change without notice.  
 Customers are advised to consult with FUJITSU sales representatives before ordering.  
 FUJITSU is unable to assume responsibility for infringement of any patent rights or other rights of third parties arising from the use of the information or package dimensions in this document.